

Tone Acoustic Booth

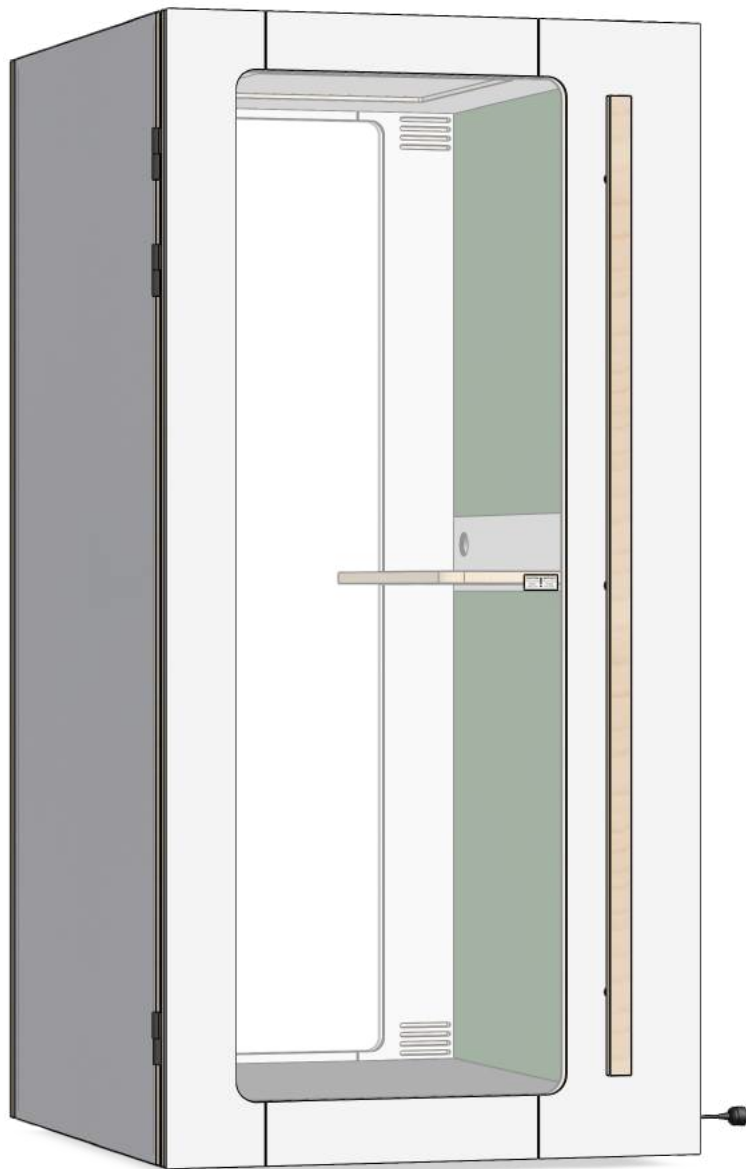

Assembly
Instructions **V1.0**

Components list

1. Base assembly

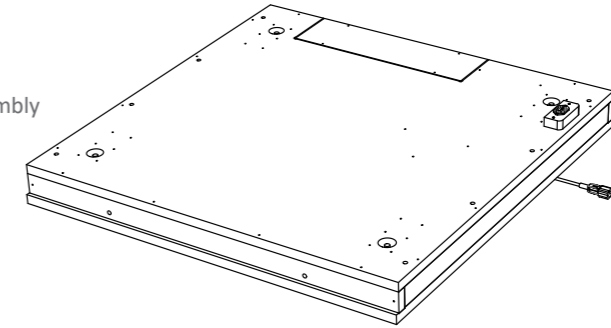

2. Left side panel assembly

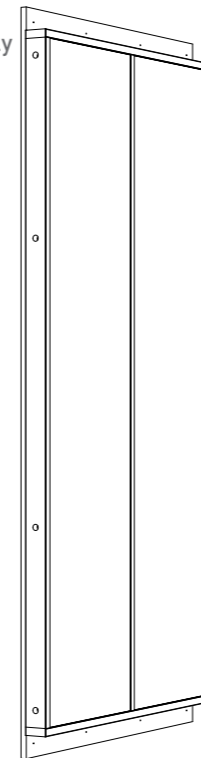

3. Right side panel assembly

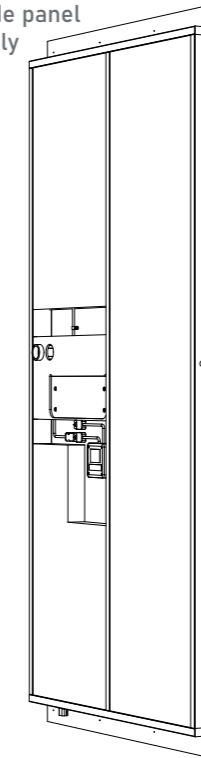

4. Top assembly

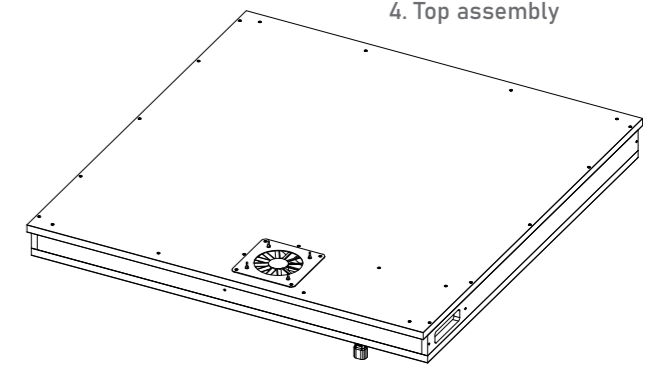

5. Rear panel assembly

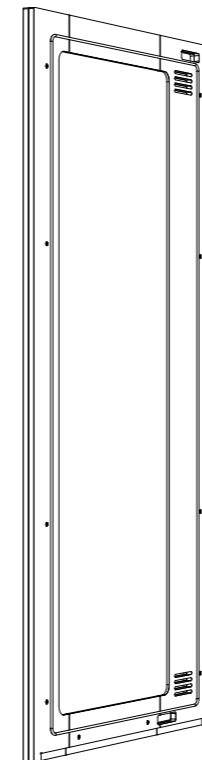

6. Internal door frame assembly

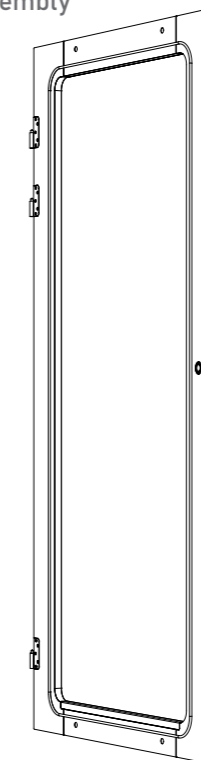

7. Internal acoustic panel left

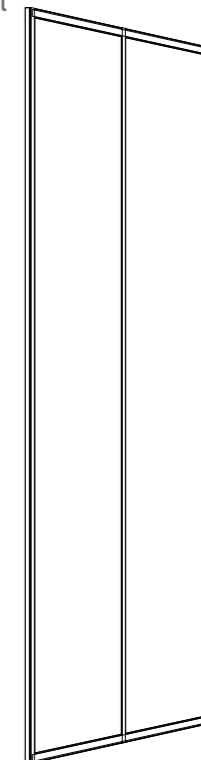

8. Internal acoustic panel right

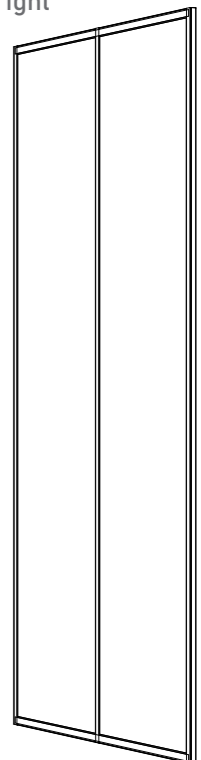

9. Door

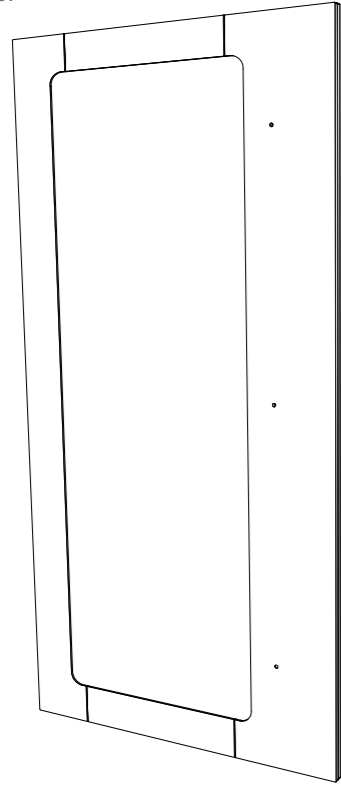

10. Carpet

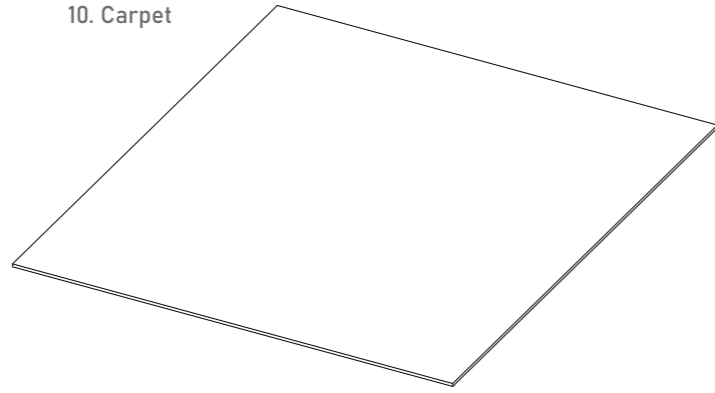

11. Upholstered side panel x2

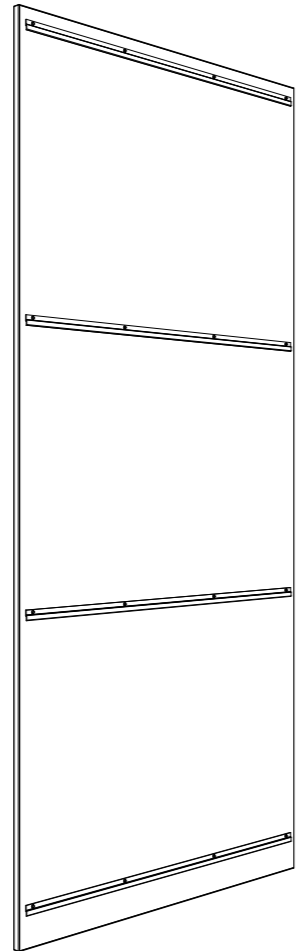

12. Exterior door handle



13 Interior door handle



14 Shelf bracket

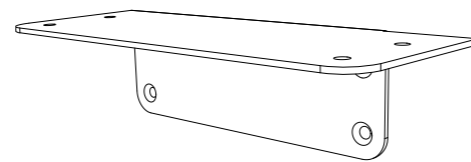

15 Shelf trim

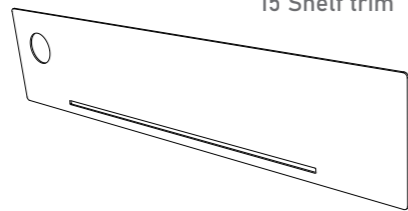

16 Shelf

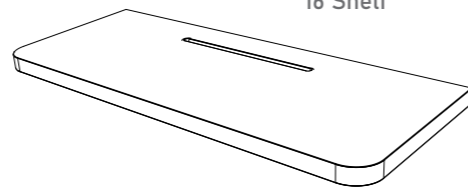

Fixings



38 Pieces
M8 x 40mm Cap head
bolt silver



8 Pieces
M10 x 16mm CSK socket
head bolt black



34 Pieces
M8 x 25mm Washer
silver



7 Pieces
M8 x 15mm Washer
silver

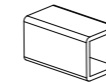

6 Pieces
Door handle spacer black



7 Pieces
M8 Bolt cap



3 Pieces
M8 x 140mm cap head
bolt silver

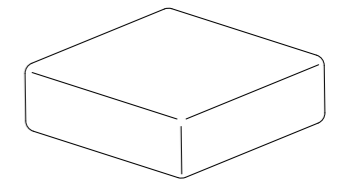

PU floor cushion

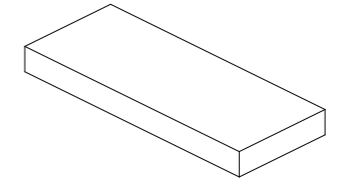

24mm Plywood spacer

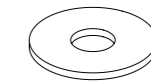

Plastic magnet spacer
shims
(2 x 0.5mm; 2 x 1.0mm)

Tools required

(not included)

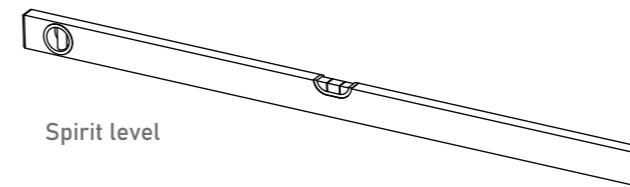

Spirit level



3mm Hex key

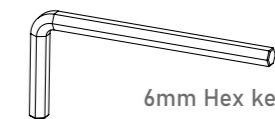

6mm Hex key



8mm
Socket

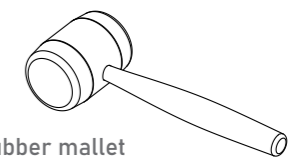

Rubber mallet

01

Unpack the booth components

Carefully remove the booth components from the delivery container and remove protective packaging.

Place the components in a safe place where they can be free from damage and protect edges from hard surfaces.

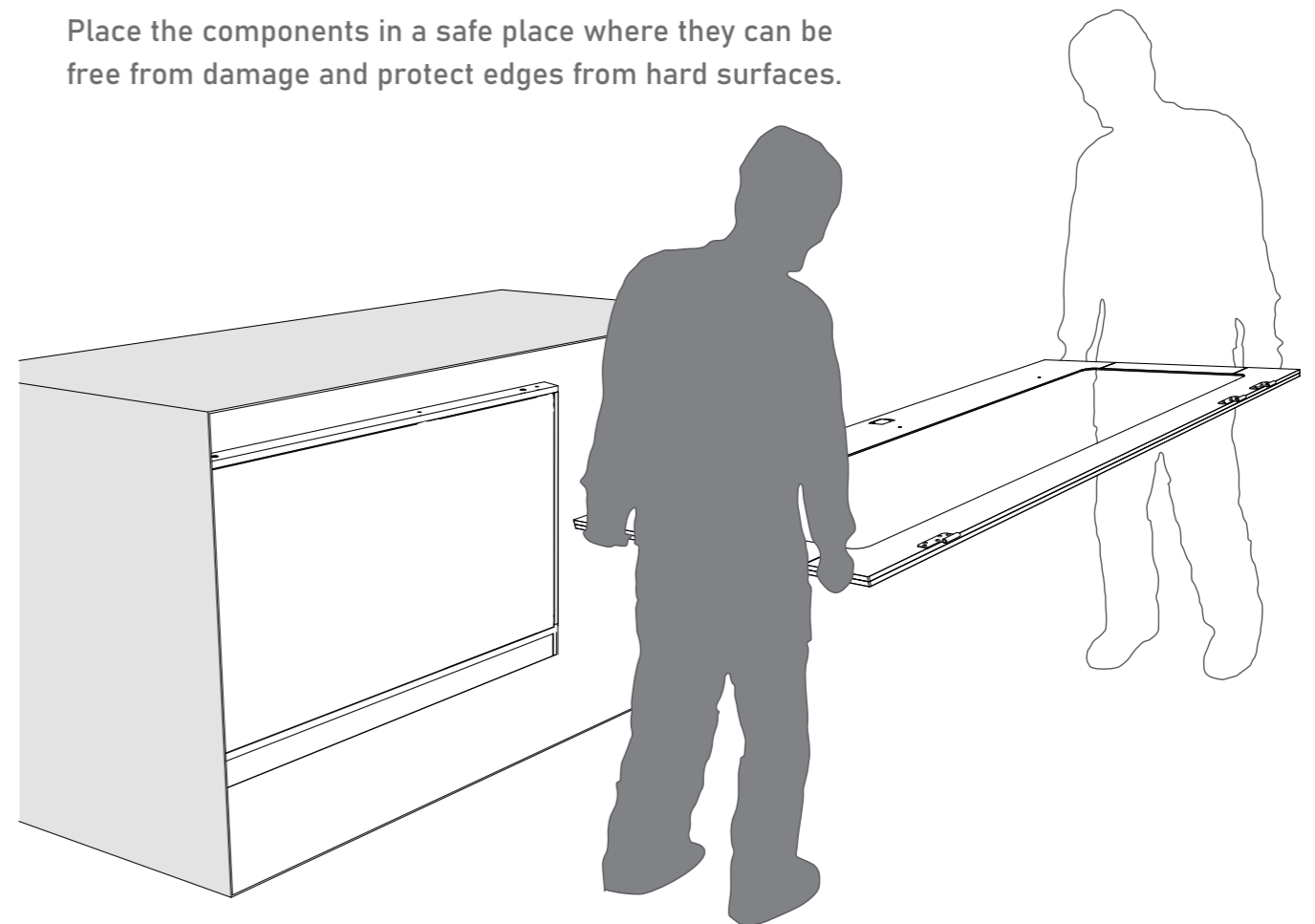

Heavy!
Two person lift required.

02

Position the base

Please ensure the base is in the correct location before assembly, allowing a minimum of 1 meter around the base and 2.5 meters of height clearance.

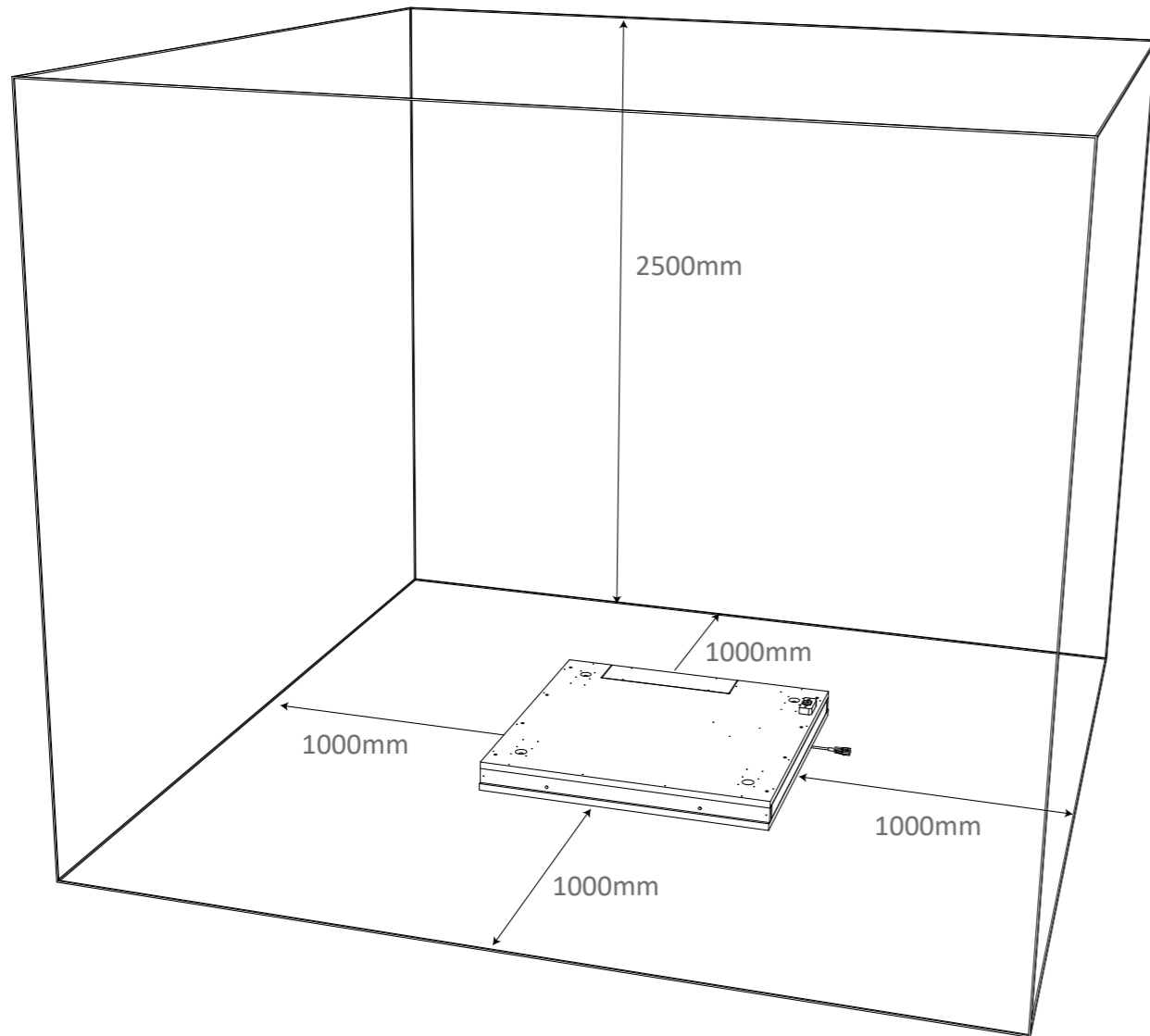

03

Level the base

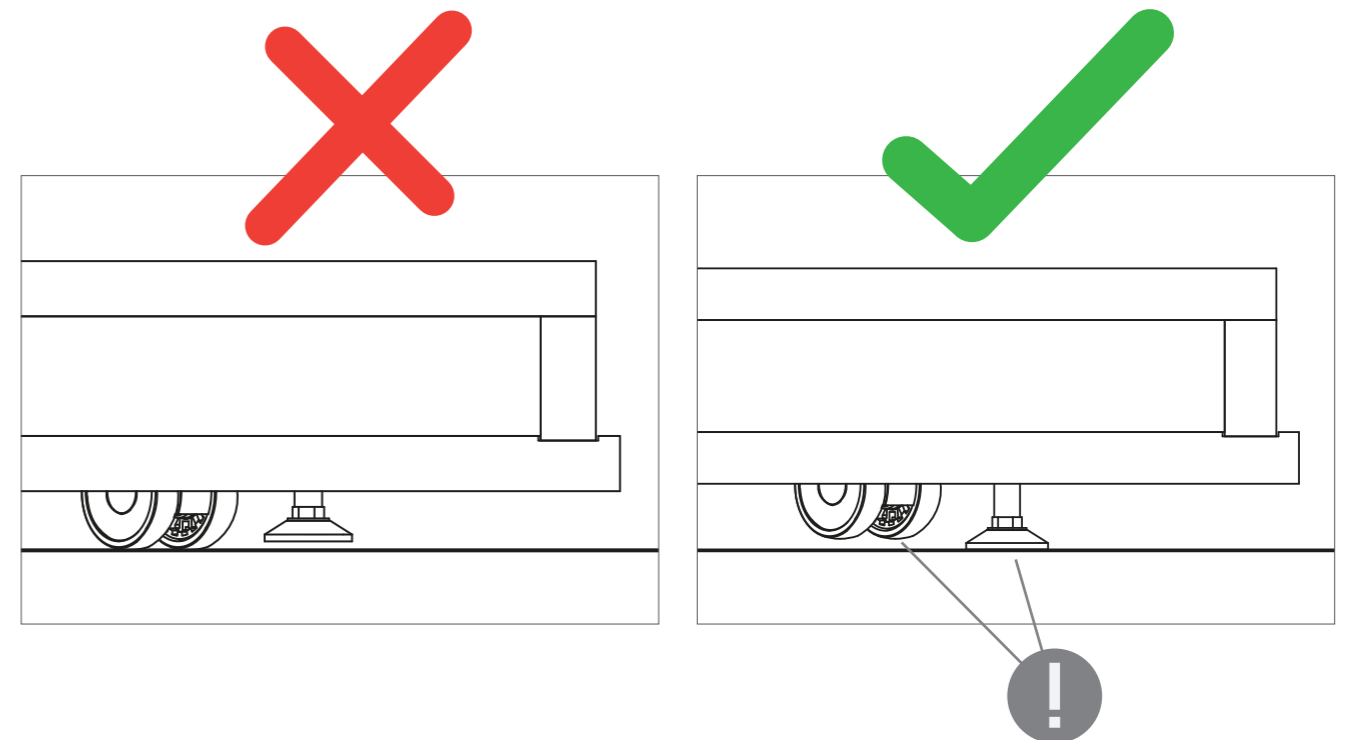
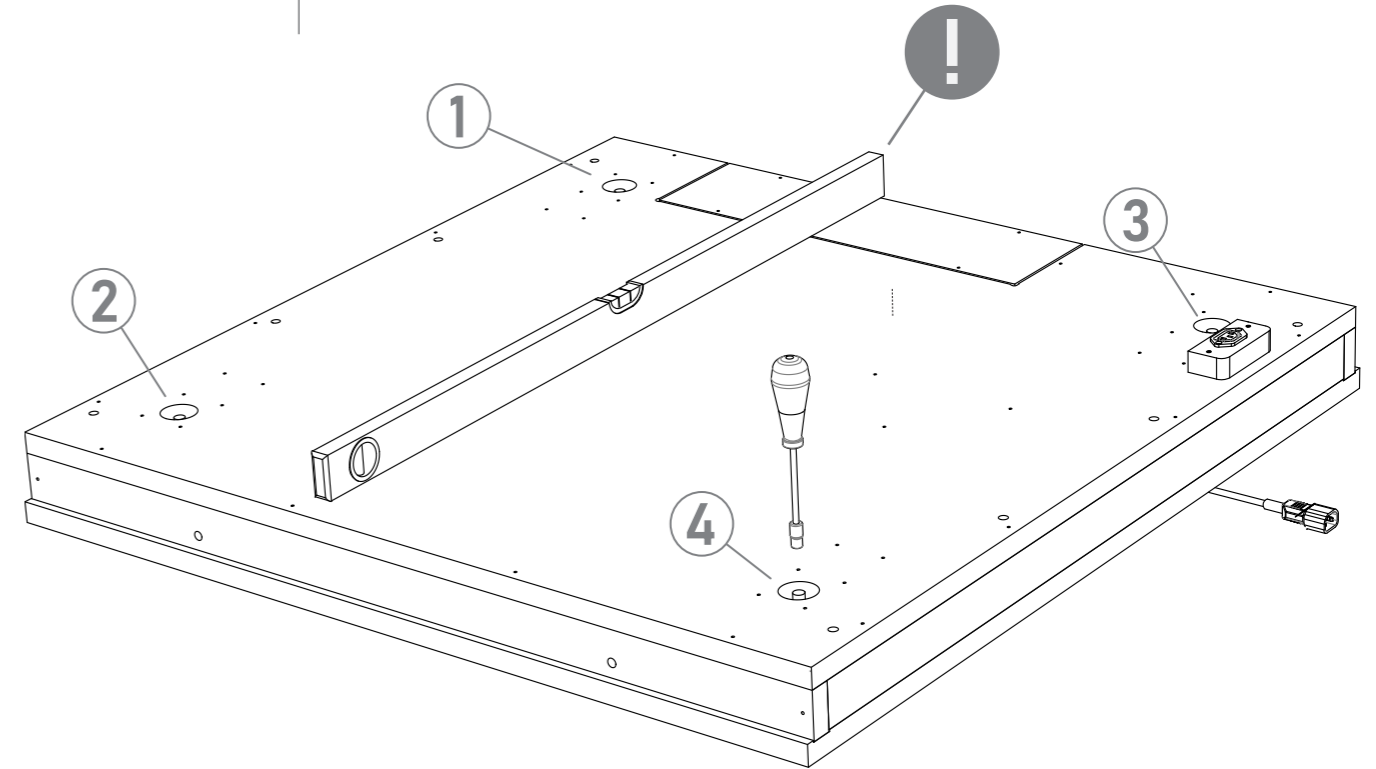
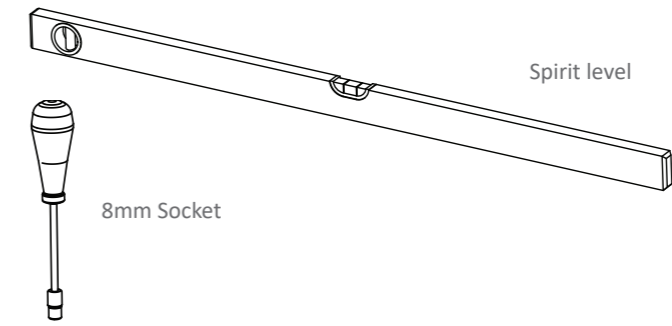

04

Remove foam from side assemblies

Left side assembly
Remove two sections

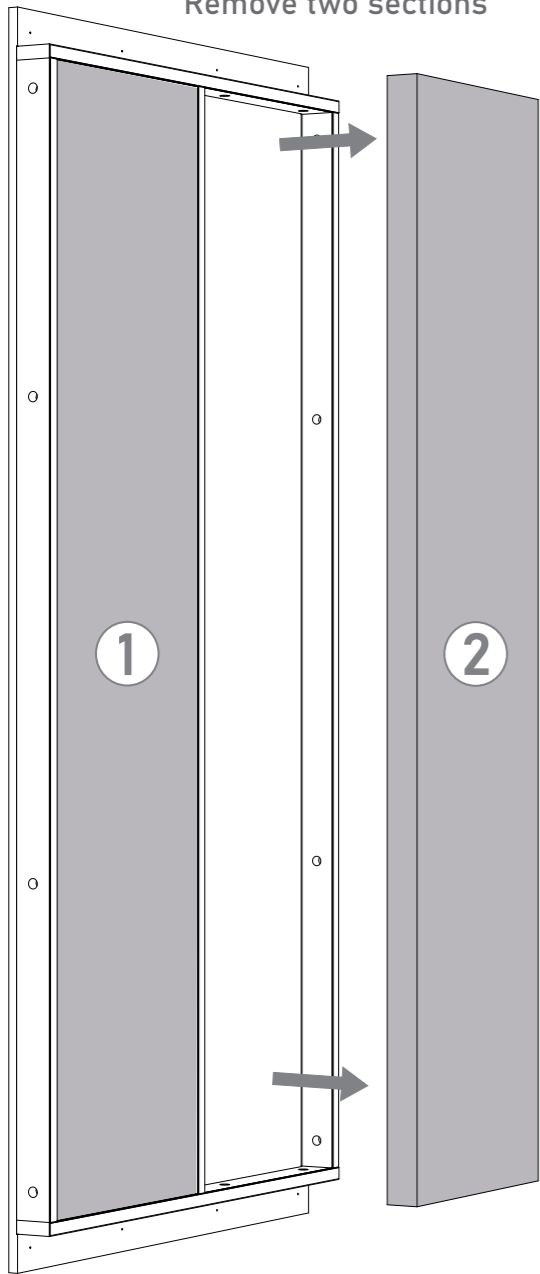

Right side assembly
Remove three sections

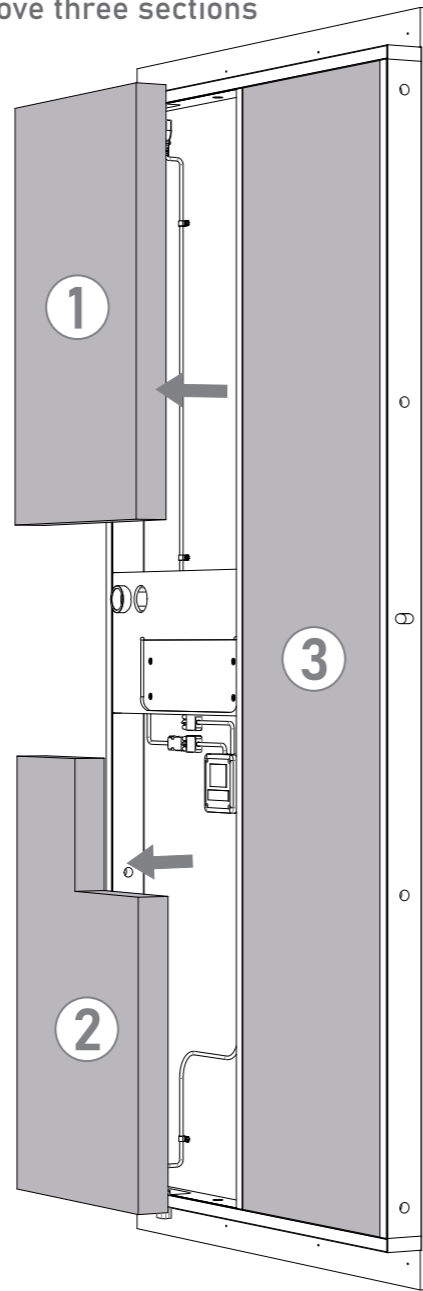

05

Fit left side panel assembly

4x  M8 Washer silver

4x  M8 x 40mm cap head bolt

 6mm Hex key

 Rubber mallet

 PU floor cushion

 **Heavy!**
Two person lift required.

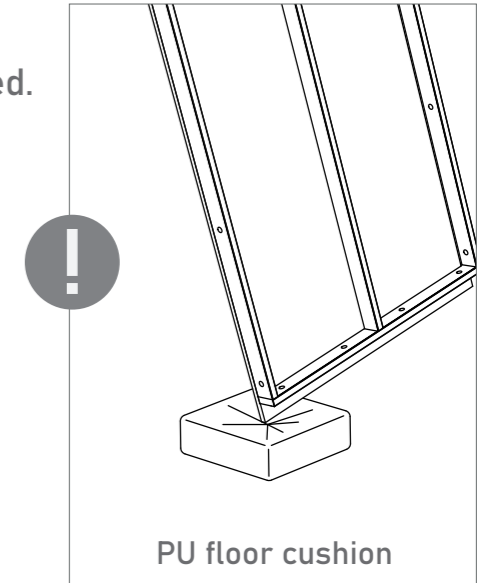
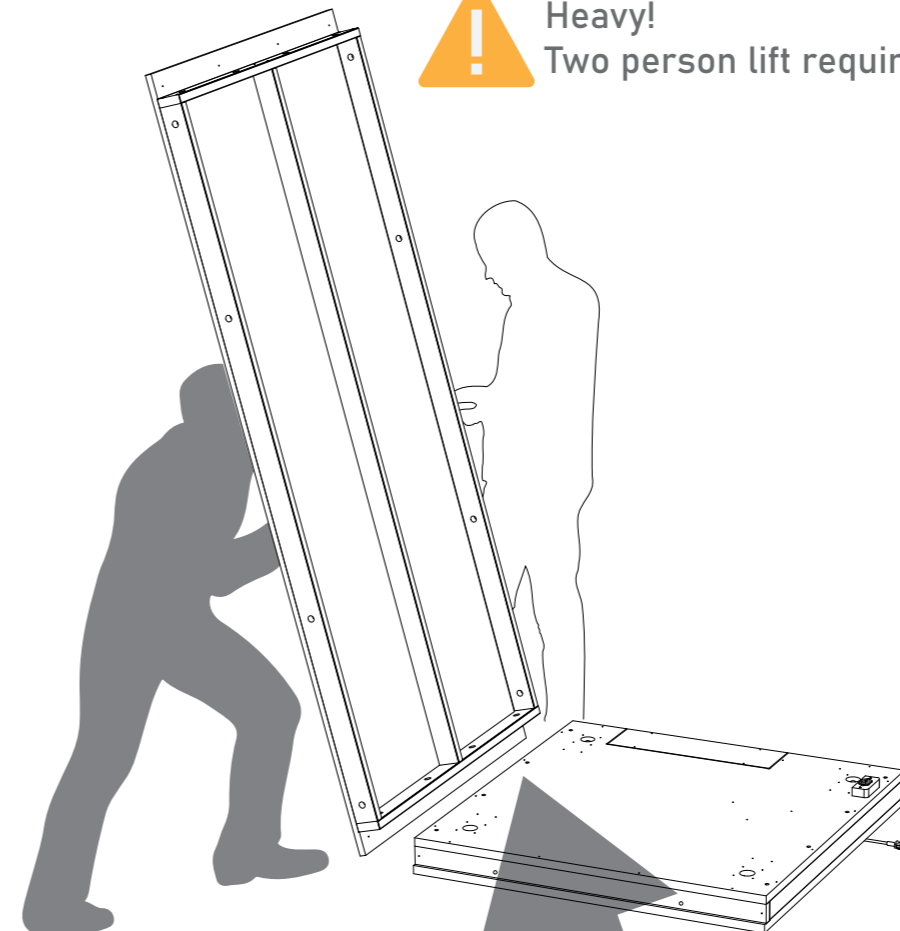

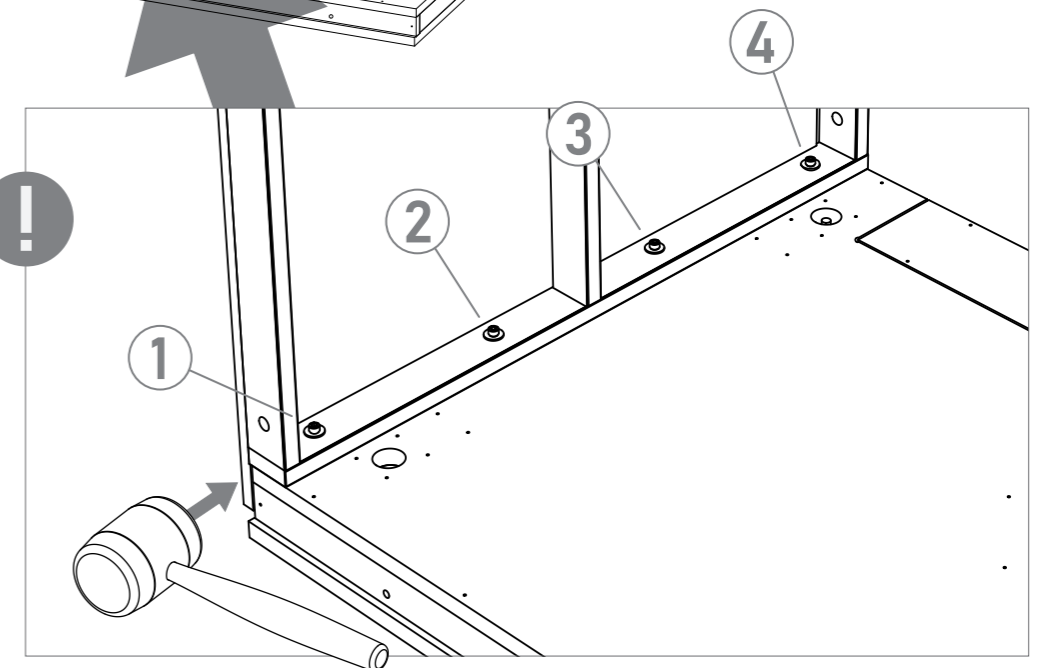

Finger tight 

Gently tap the front edge with the rubber mallet to align.

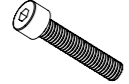

06

Fit right side panel assembly

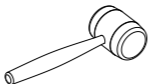
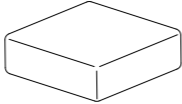
- 4x  M8 Washer silver
- 4x  M8 x 40mm cap head bolt
-  6mm Hex key
-  Rubber mallet
-  PU floor cushion

 **Heavy!**
Two person lift required.



07

Remove floor access panel

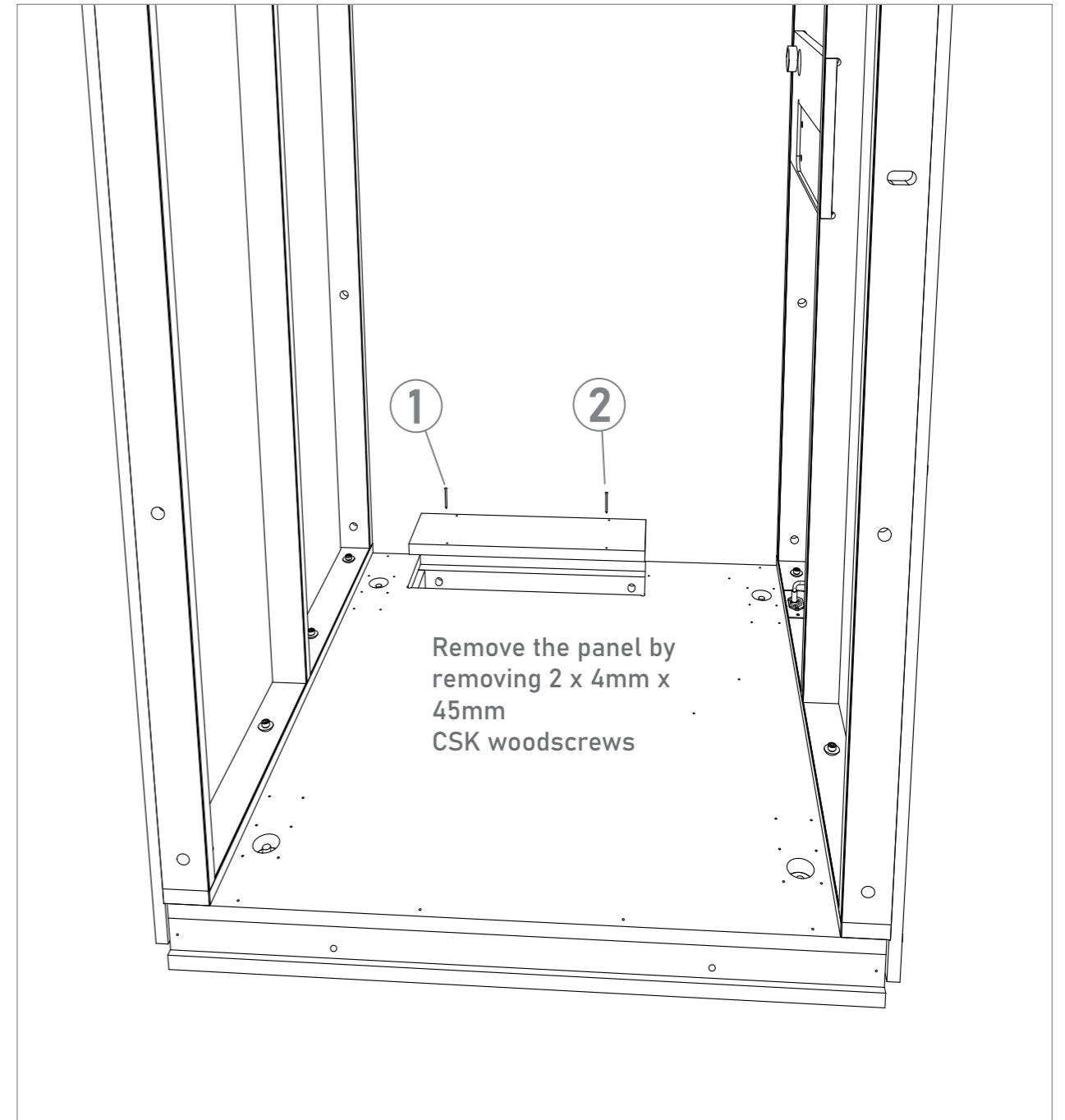

08

Fit back panel assembly

 Heavy!
Two person lift required.

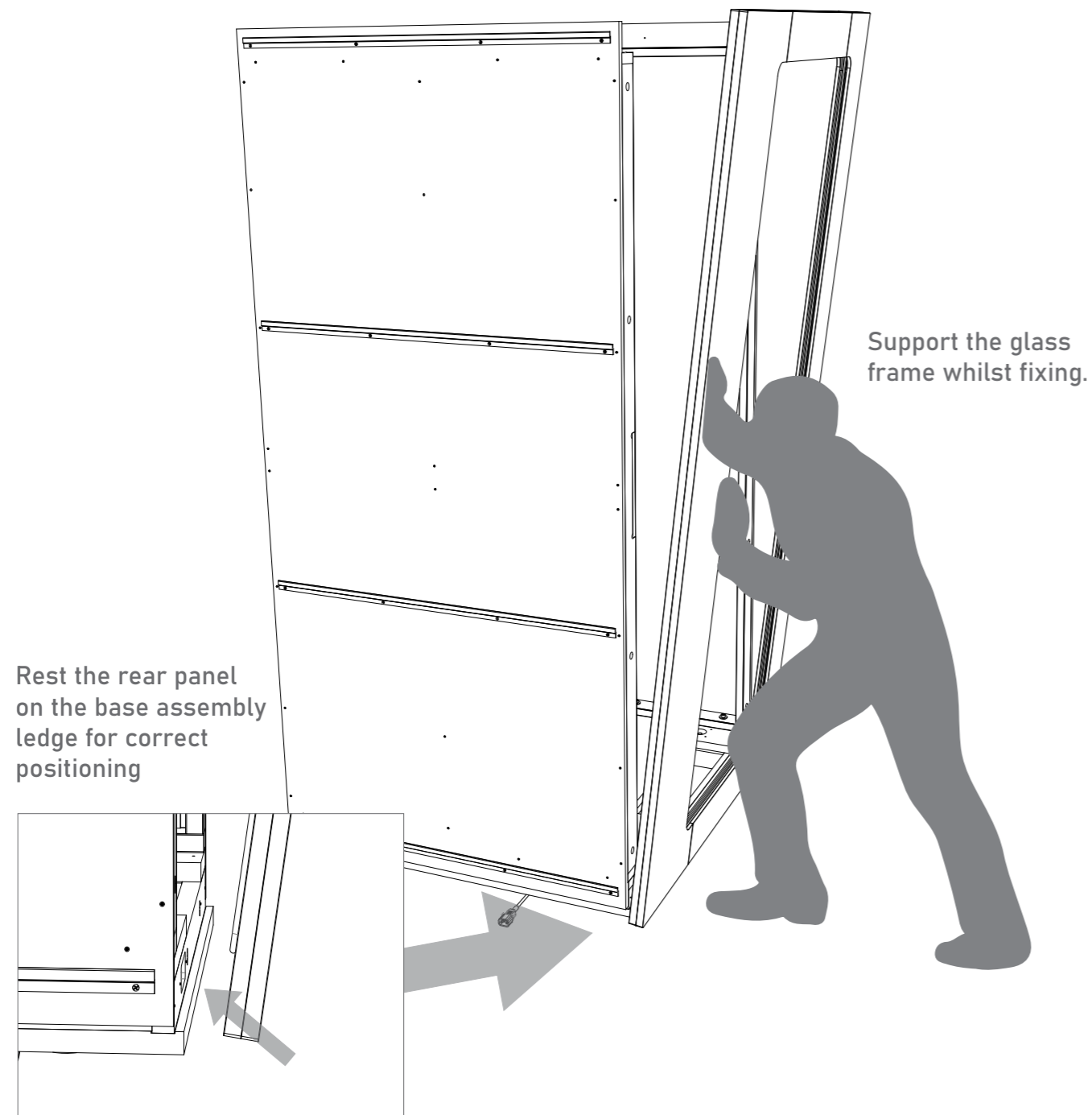

09

Fix back panel assembly

- 10x  M8 Washer silver
- 10x  M8 x 40mm cap head bolt
-  6mm Hex key

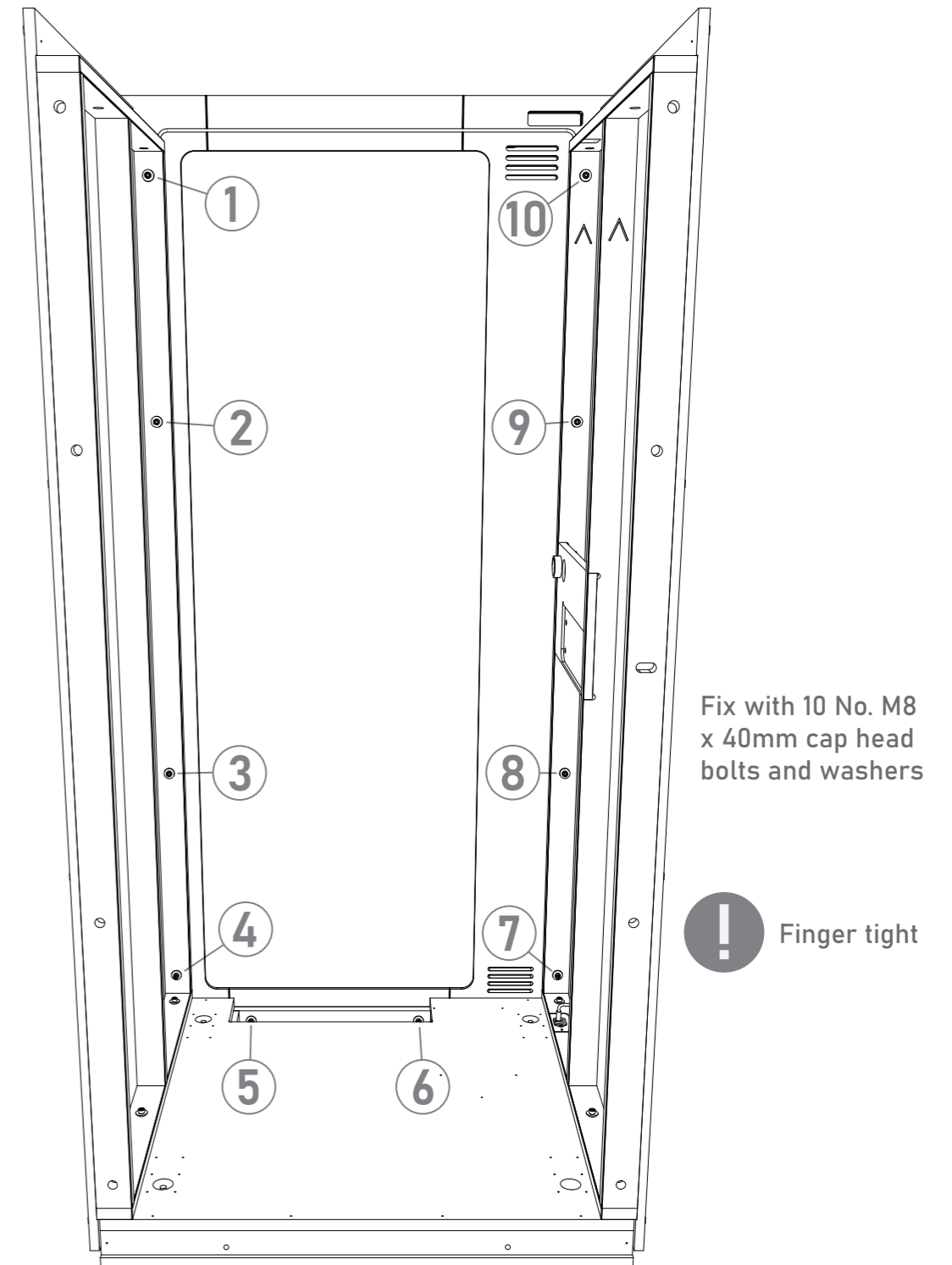

10

Position top panel assembly

 **Heavy!**
Two person lift required.

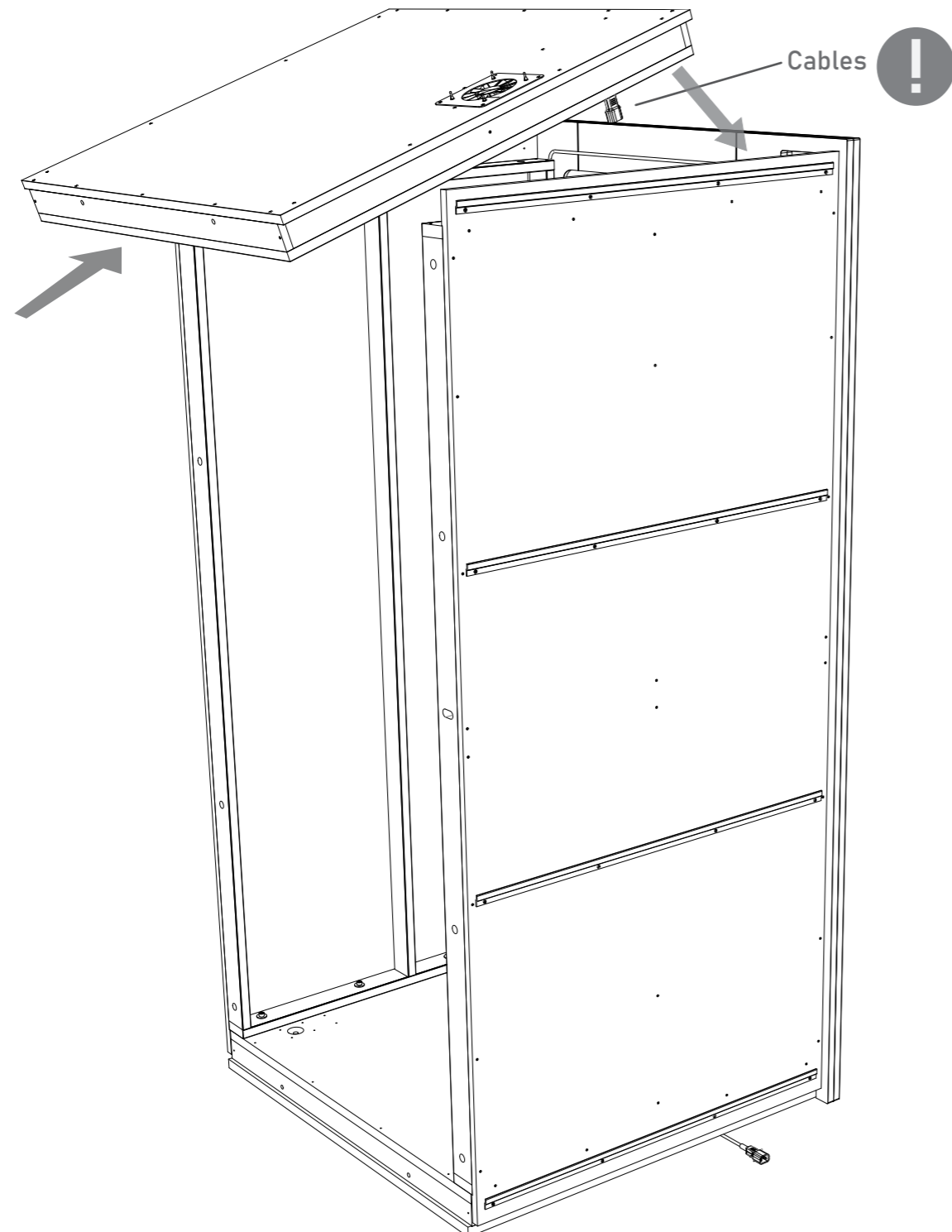

11

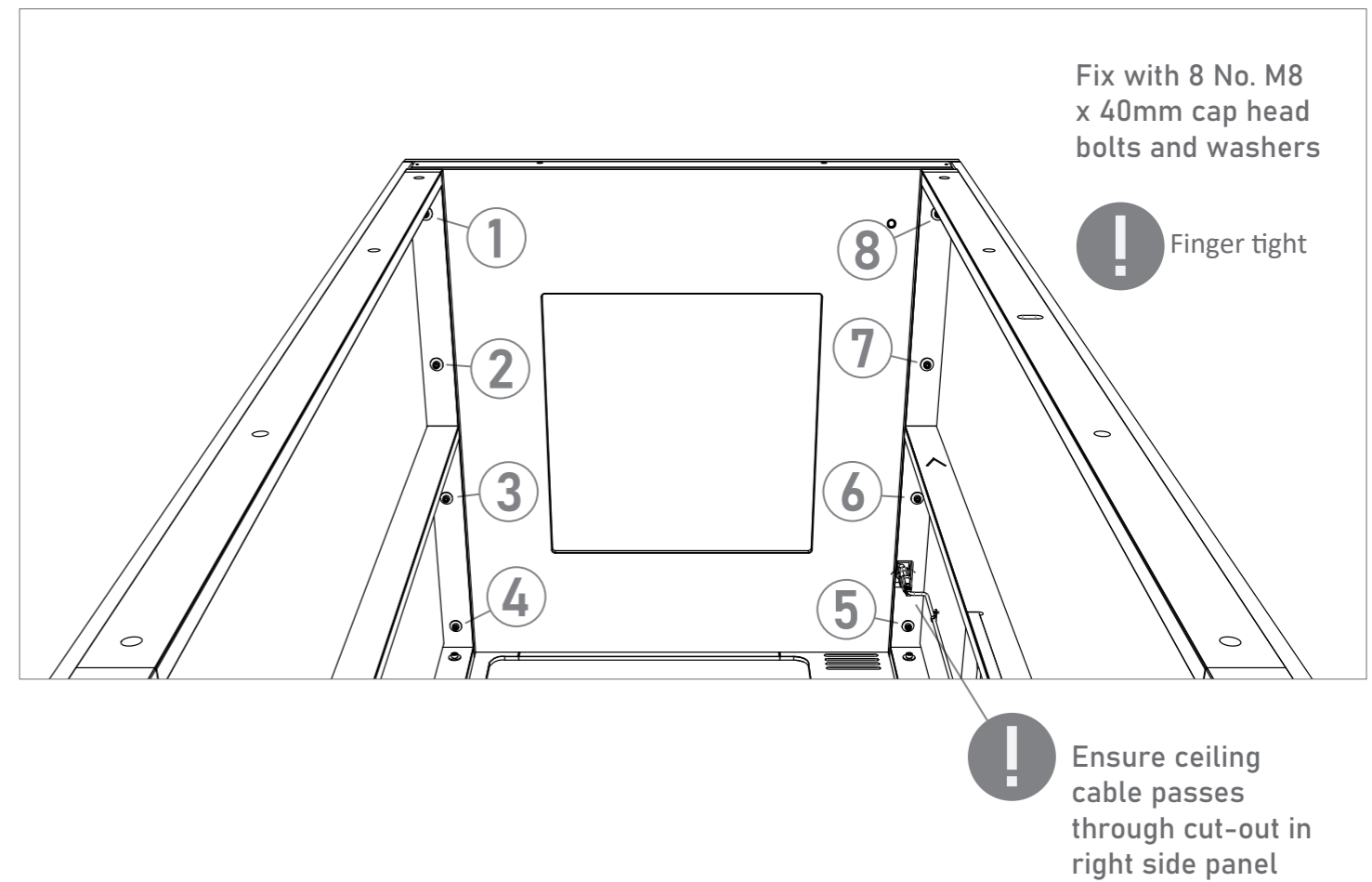

Fix top panel assembly

- 8x  M8 Washer silver
- 8x  M8 x 40mm cap head bolt
-  Rubber mallet
-  6mm Hex key

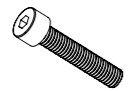

12

Fit front door frame panel assembly interior

- 8x  M8 Washer silver
- 8x  M8 x 40mm cap head bolt silver
-  6mm Hex key

 Finger tight

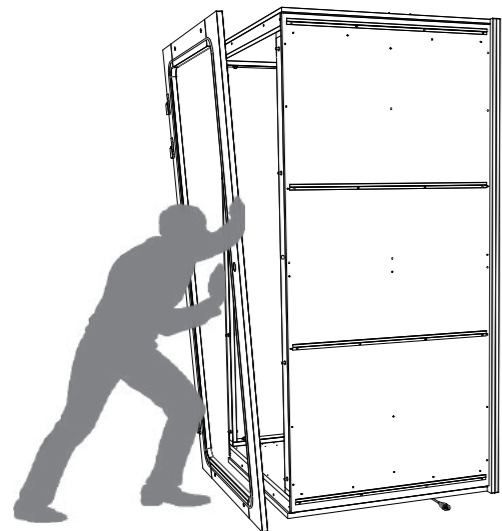

Rest the front door frame panel on the base assembly ledge for correct positioning

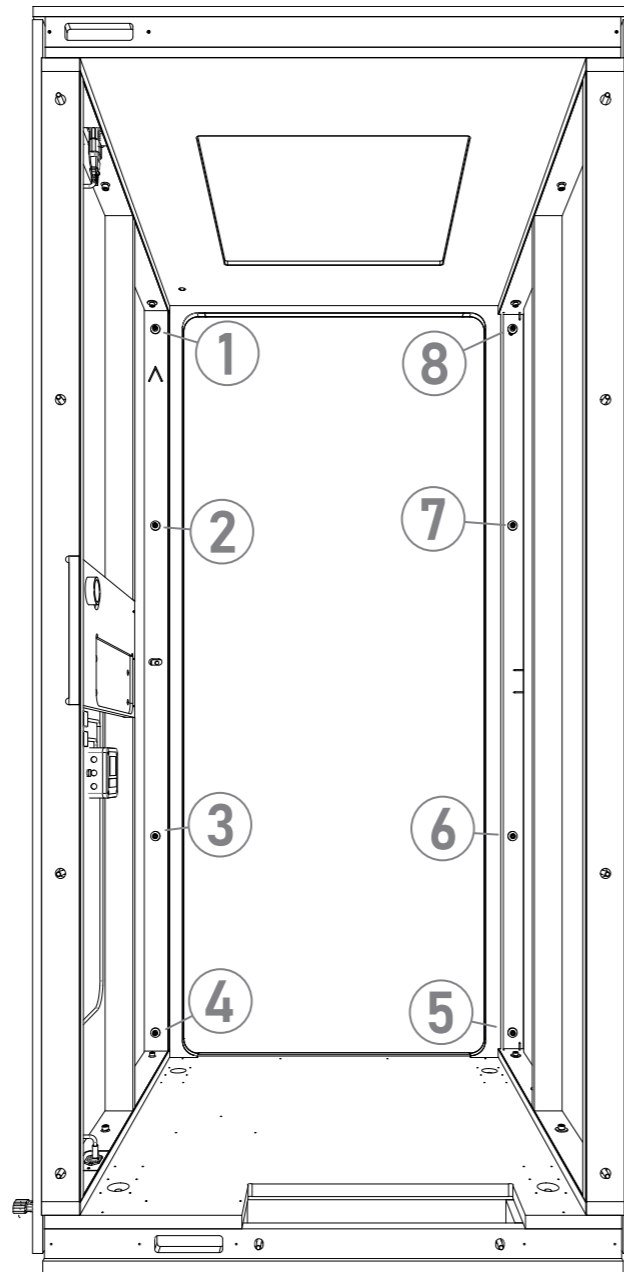
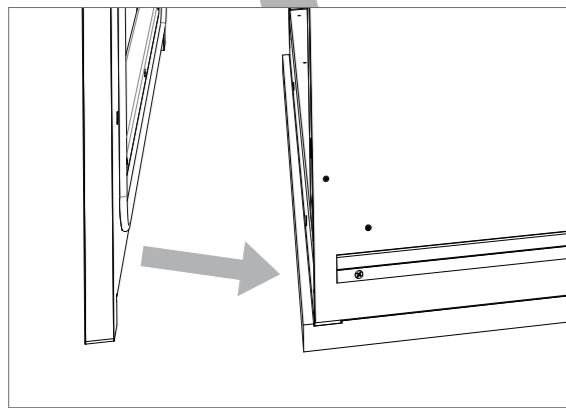



Fix with 8 No. M8 x 40mm cap head bolts and washers

View from the rear with the back panel removed

13

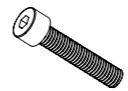
Fit front door frame panel assembly exterior

- 4x  M8 Cap head bolt cover
- 4x  M8 x 40mm cap head bolt silver
- 4x  M8 x 15mm washer
-  6mm Hex key

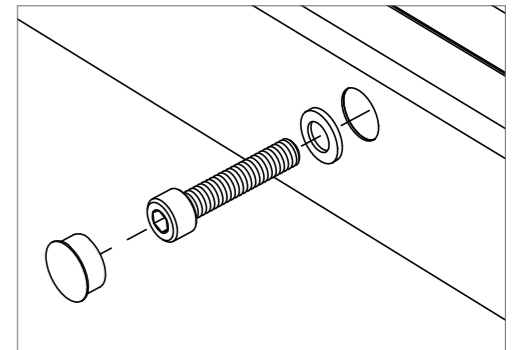
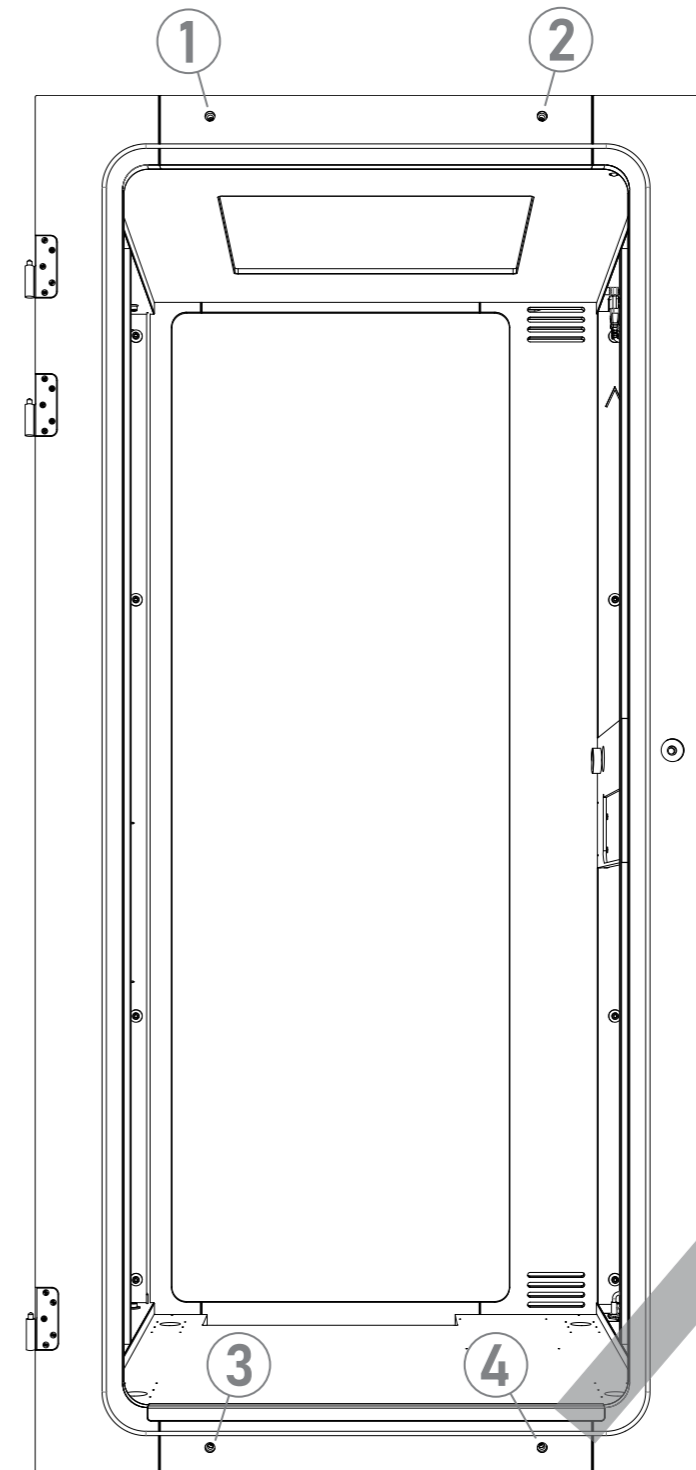

Fix with 4 No. M8 x 40mm cap head bolts, 4 No. M8 x 15 washers and cap head bolt covers

14

Align side panels and tighten all fixings

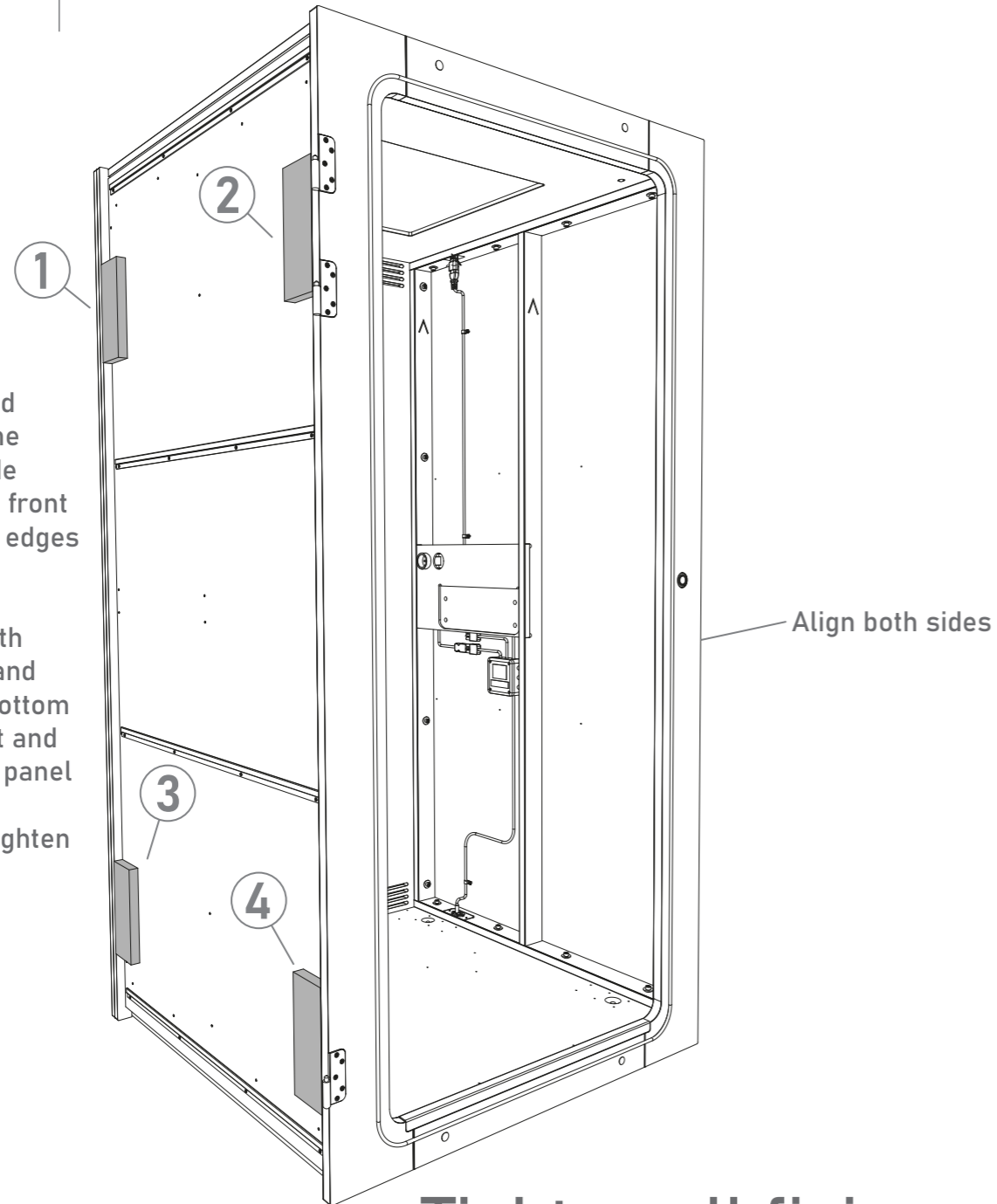
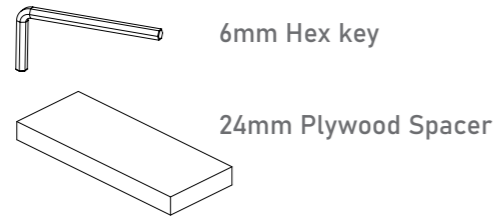

Use the plywood spacer to set the depth of the side panels with the front and back panel edges to 24mm.

Ensure the depth is 24mm front and back, top and bottom and on both left and right hand side panel assemblies. Once aligned, tighten all fixings.

**Tighten all fixings.
Do not over tighten.**

15

Replace floor panel

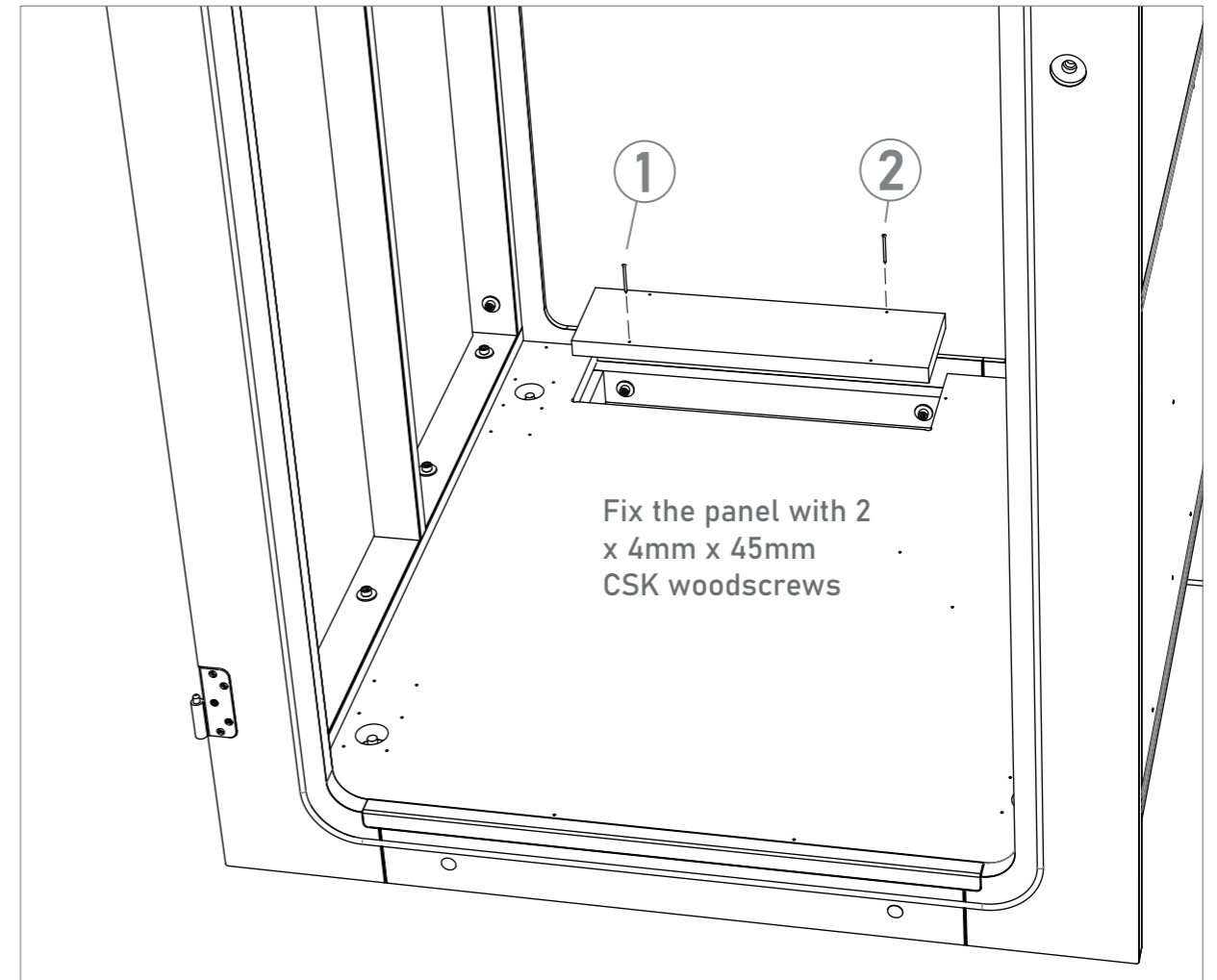

16

Connect electric cables

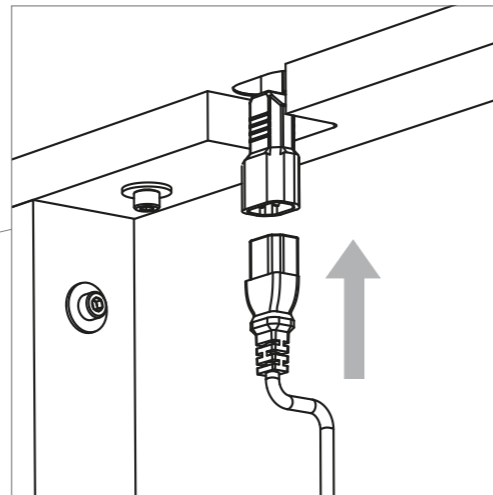
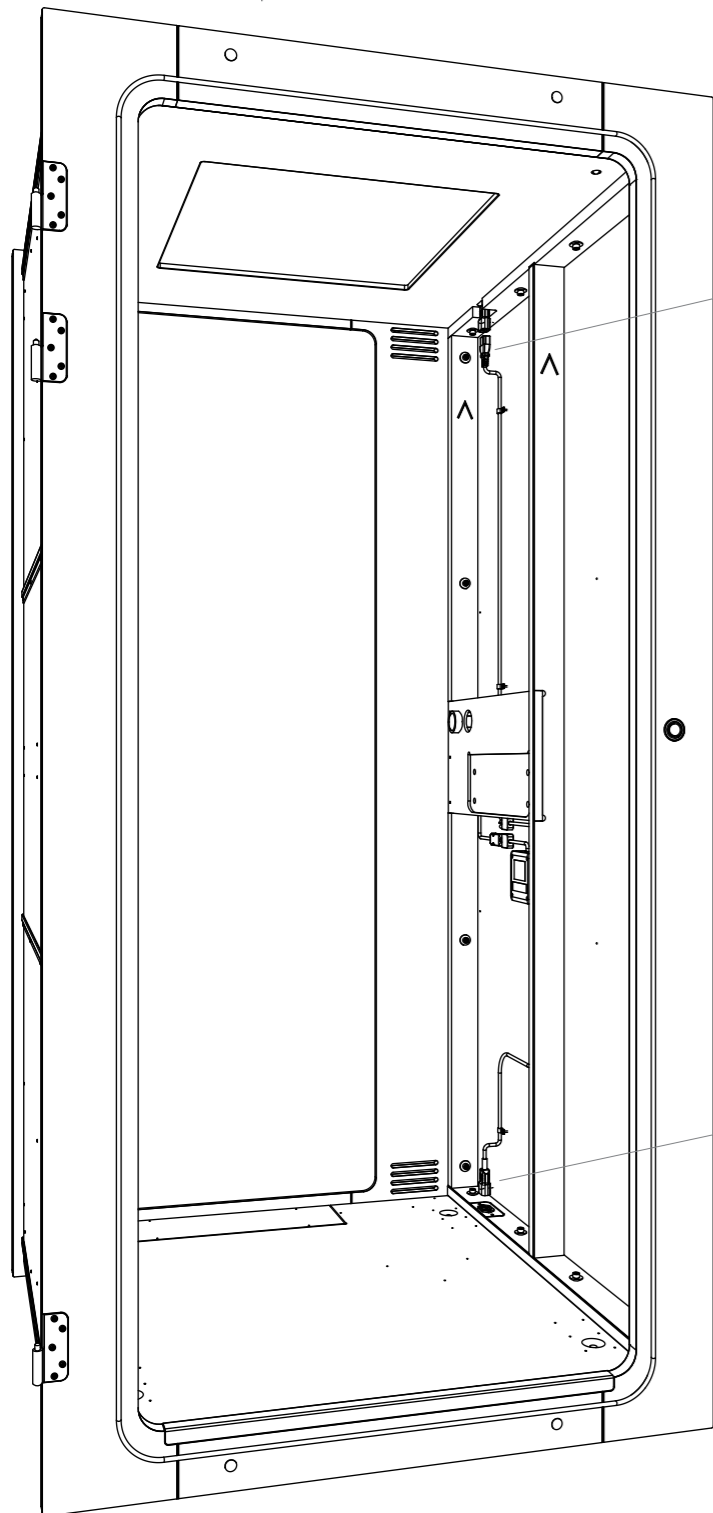

Connect the electric cables to the top and bottom of the right hand panel assembly

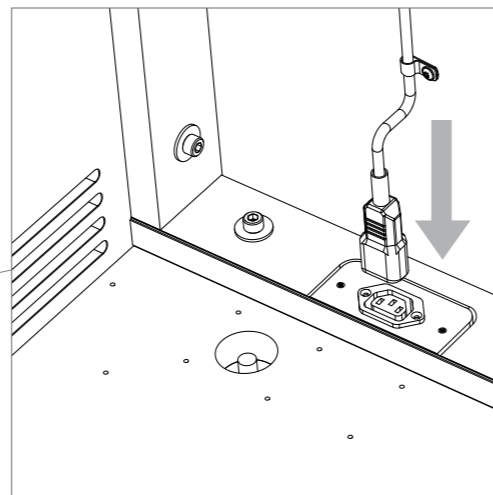

17

Fit the shelf bracket

4x  M10 x 16mm CSK bolt

 6mm Hex key

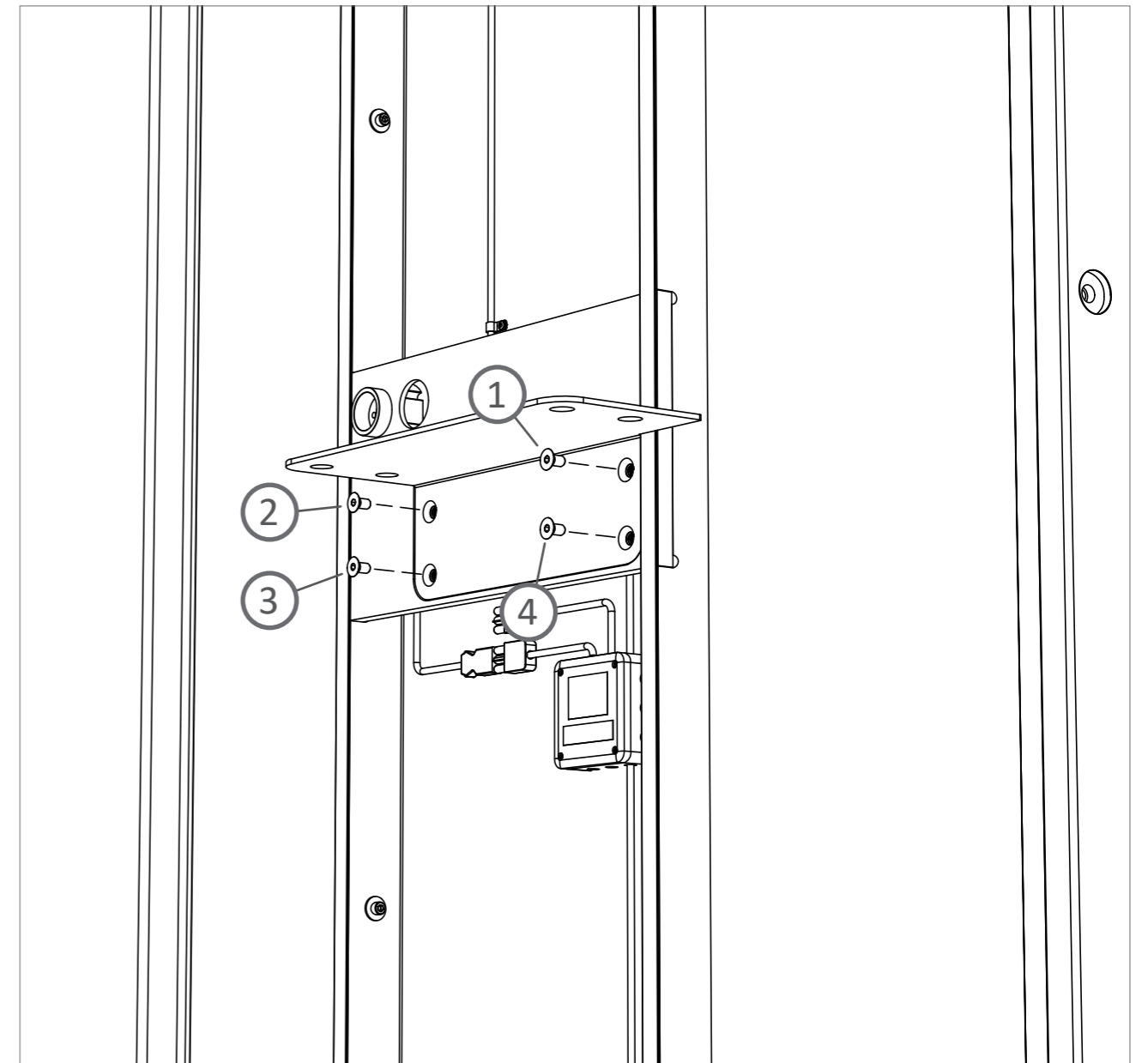

18

Replace foam - right panel assembly

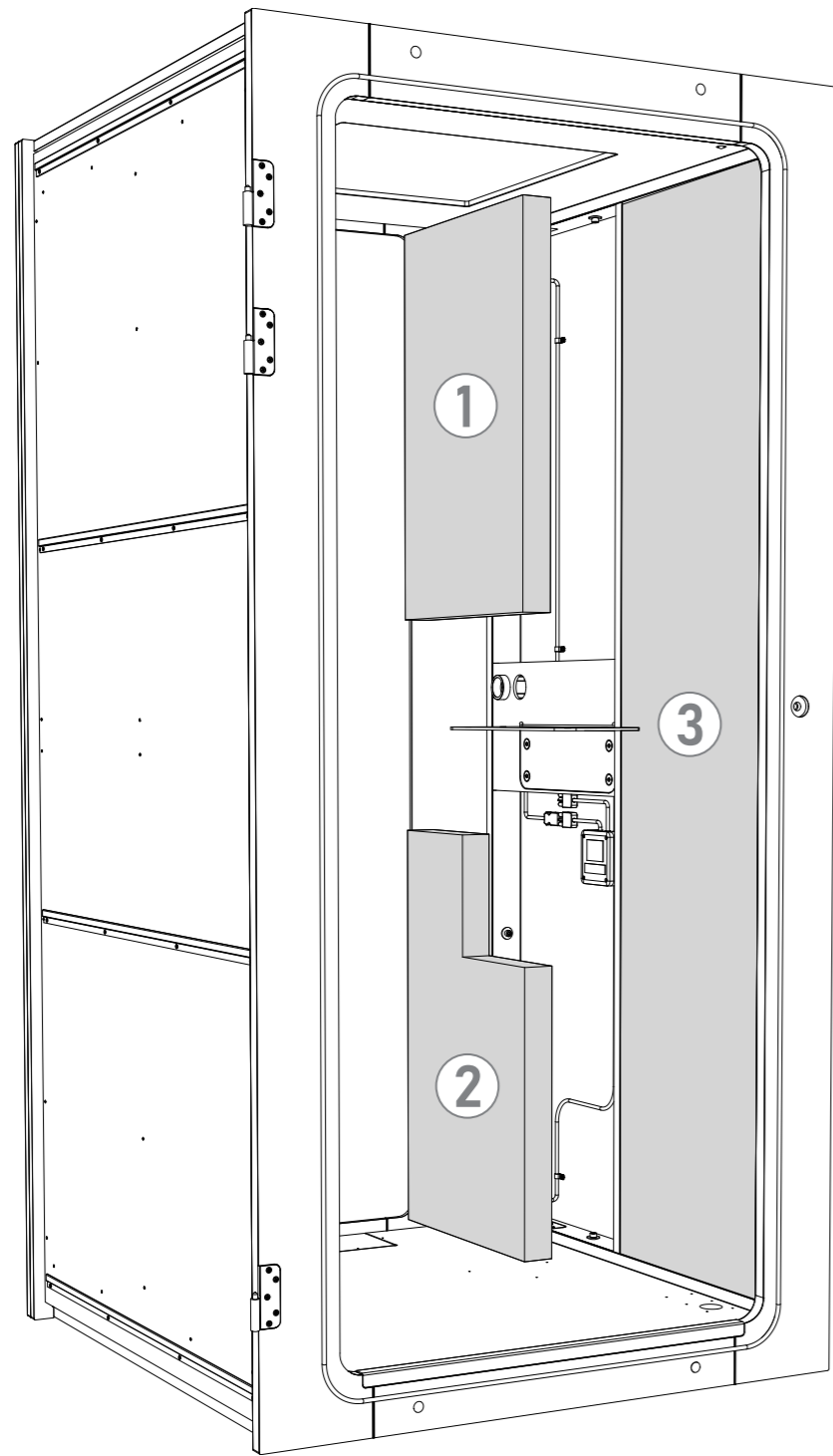

19

Replace foam - left panel assembly

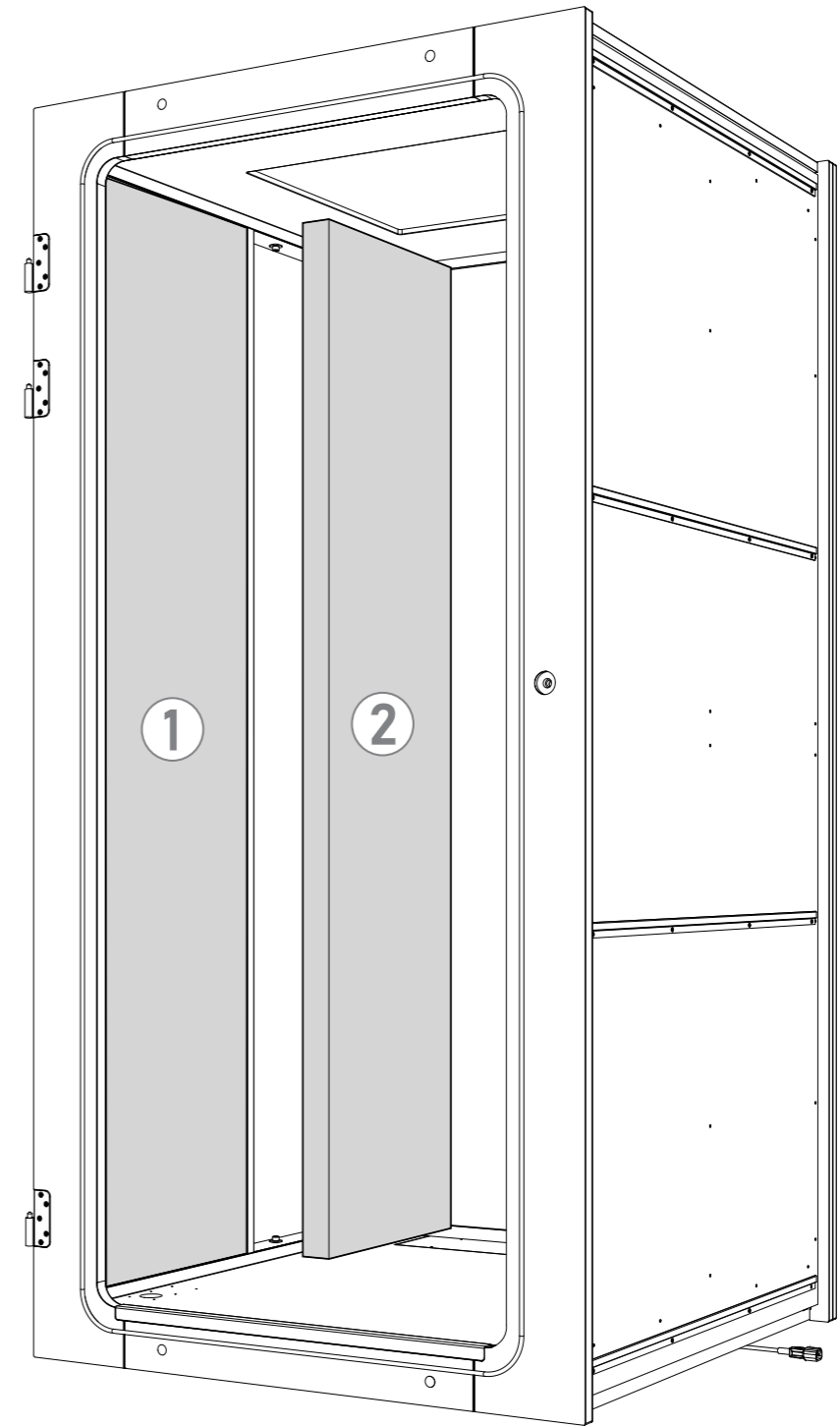

20

Fit the carpet

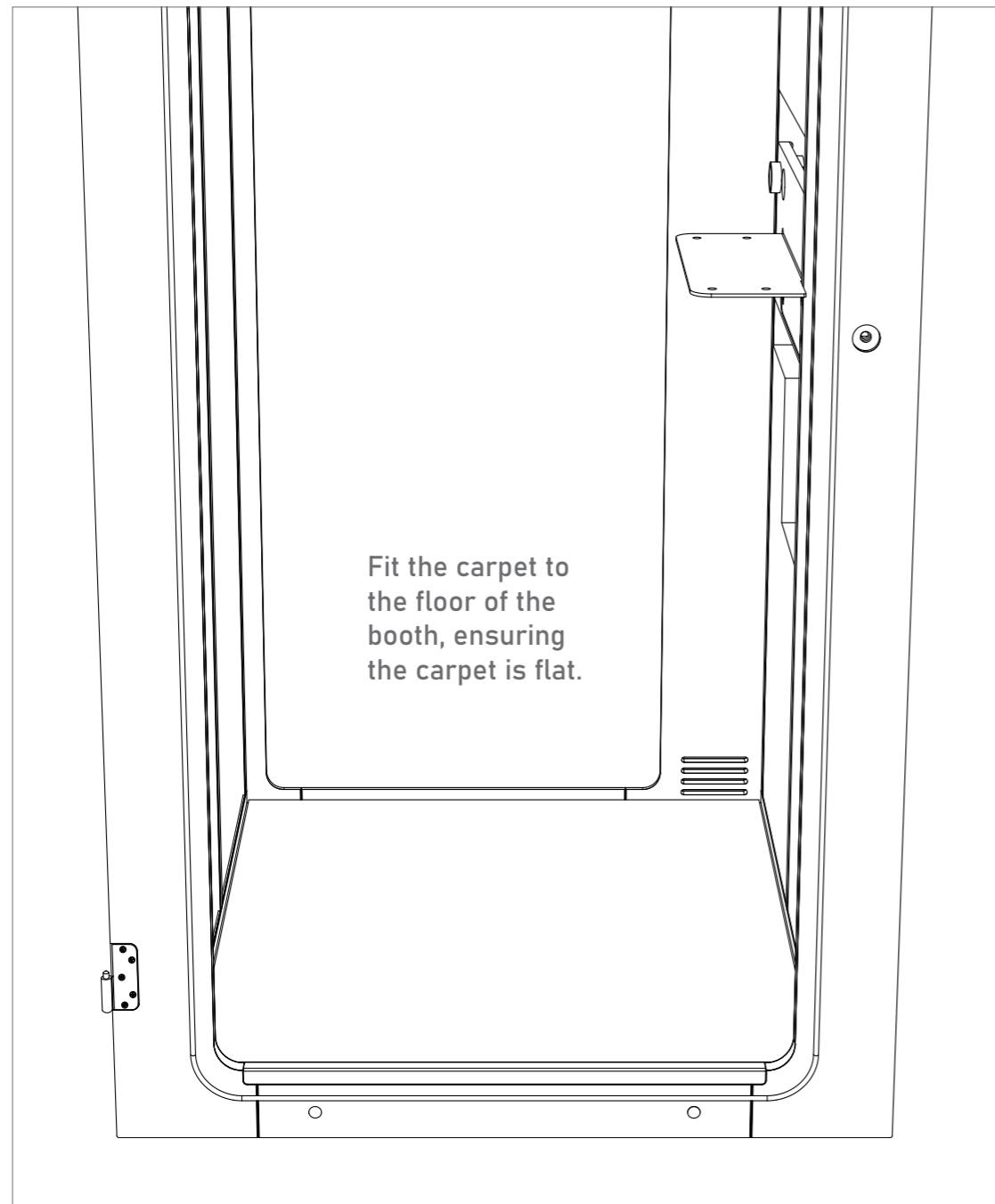

21

Fit the internal right side panel

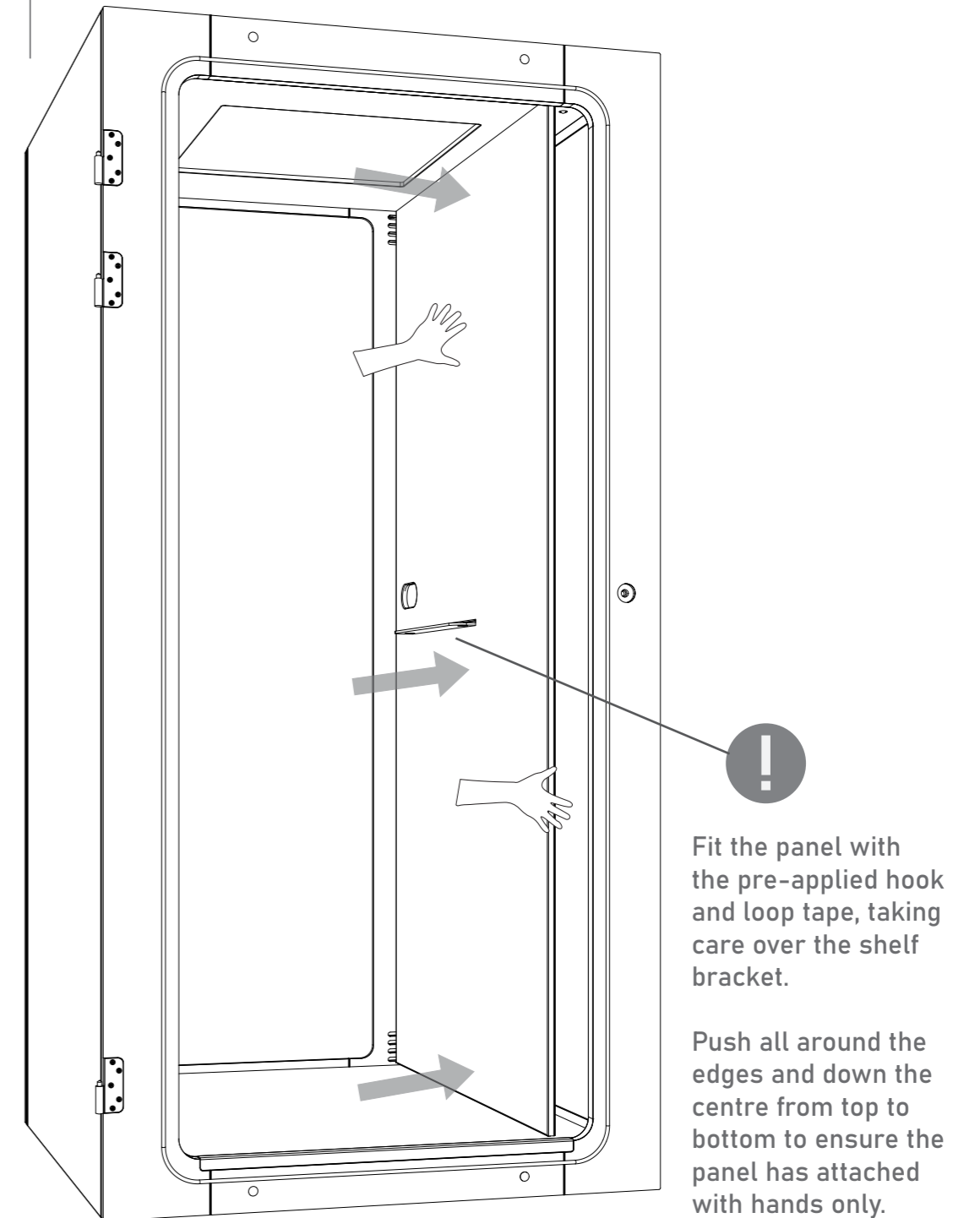

22

Fit the internal left side panel

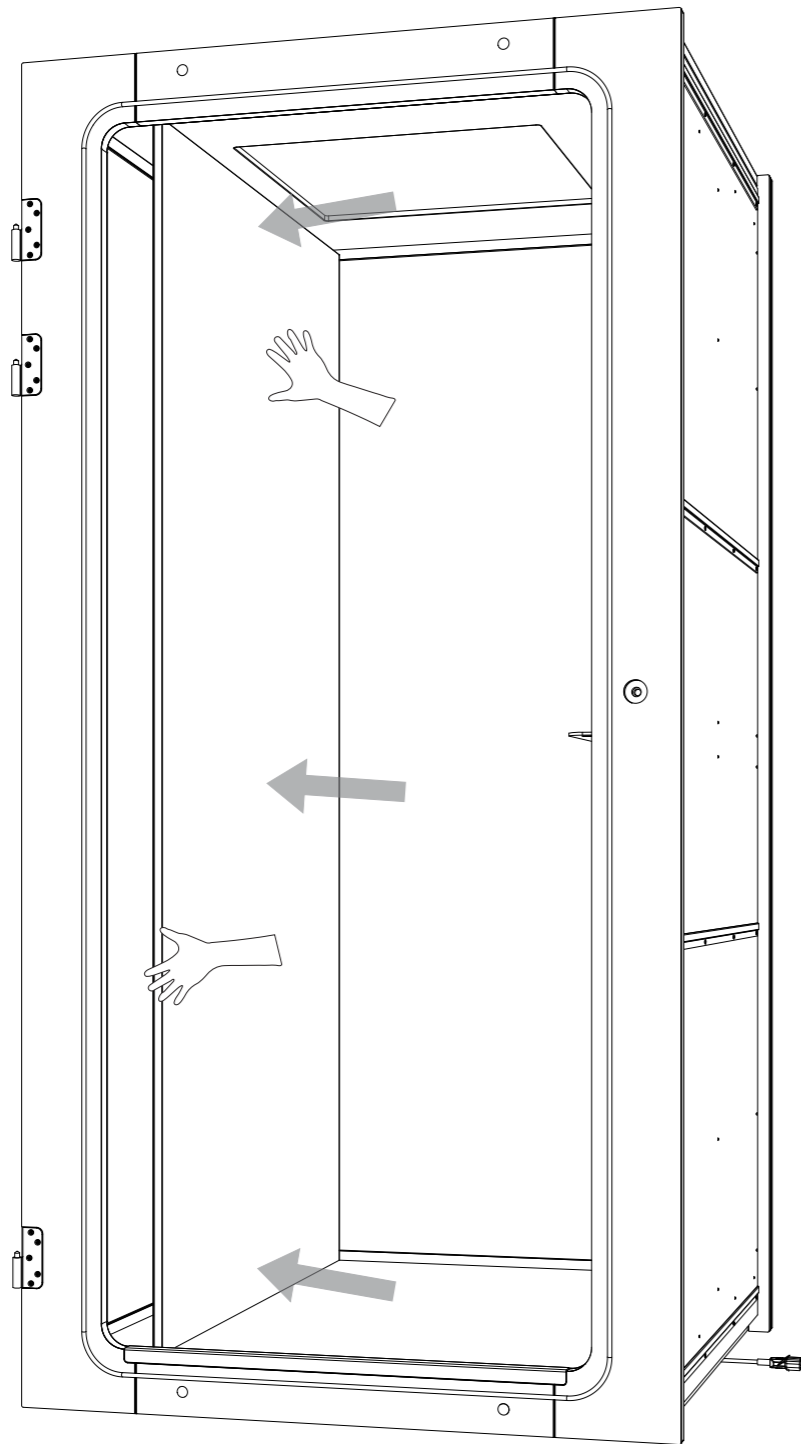

Fit the panel with the pre-applied hook and loop tape.

Push all around the edges and down the centre from top to bottom to ensure the panel has attached with hands only.

23

Fit the shelf and trim

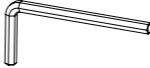
- 4x  M10 x 16mm CSK bolt
-  6mm Hex key

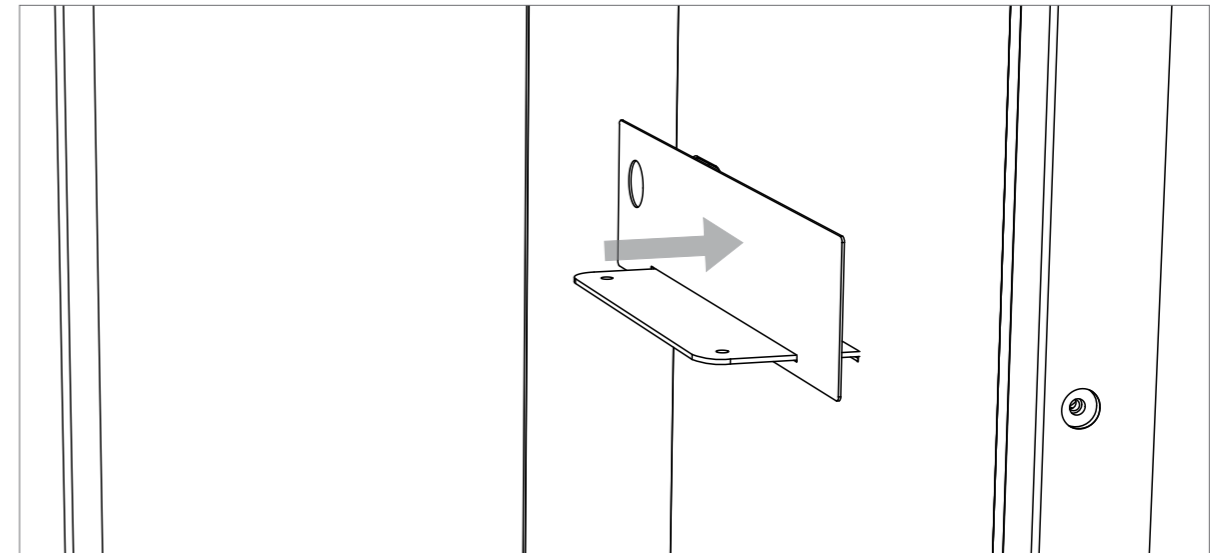

1 Slide the shelf trim over the shelf supporting bracket.

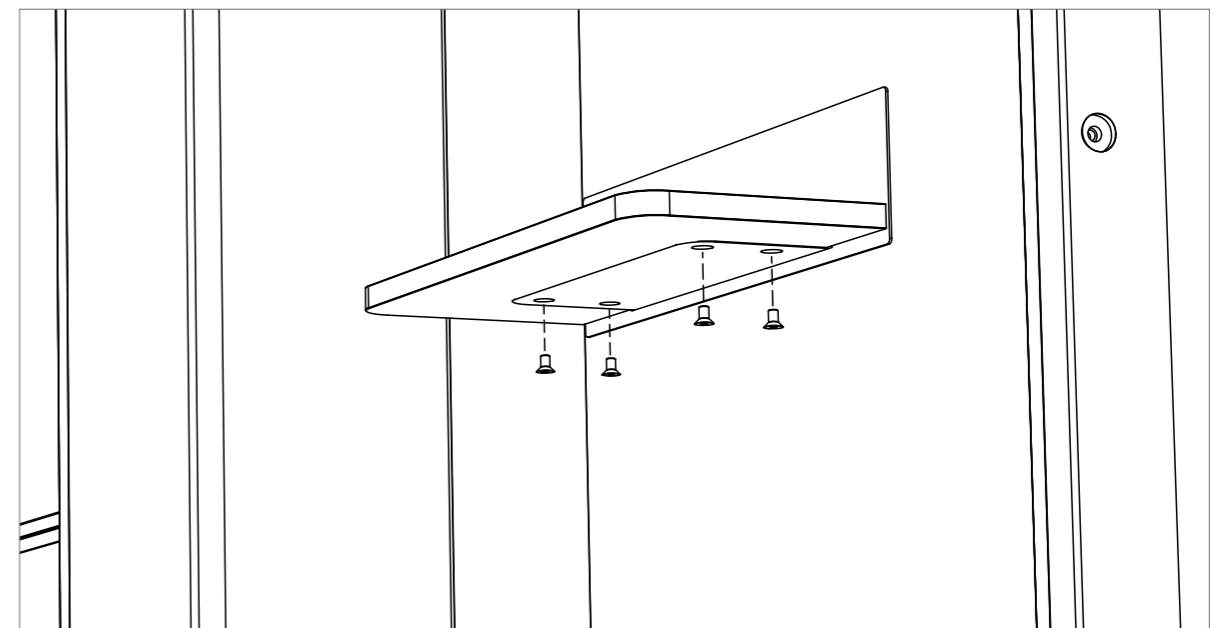

2 Place the shelf on the supporting bracket and fix using 4x M10 x 16mm CSK bolts

24

Fit the upholstered left side panel

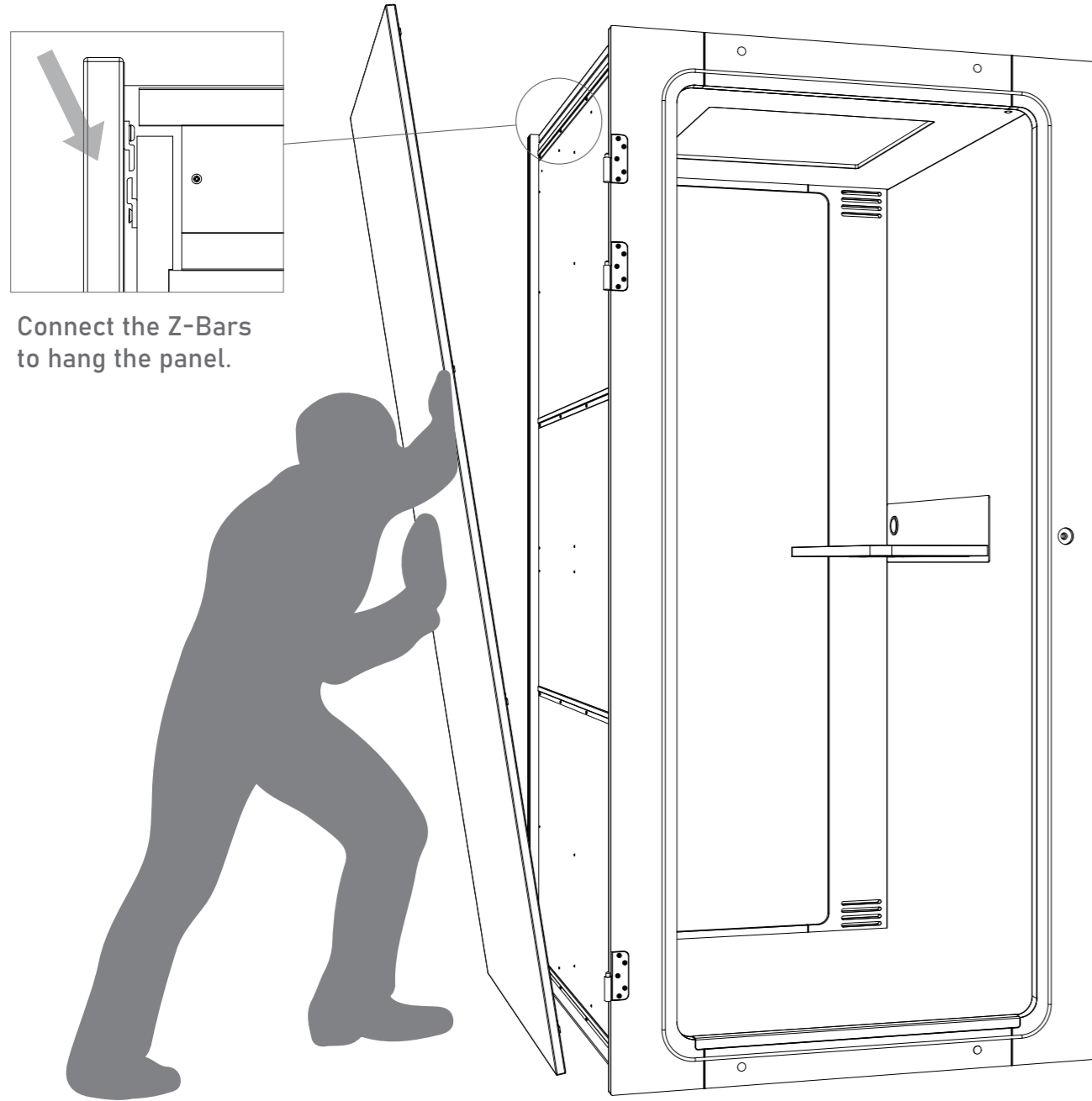

Connect the Z-Bars to hang the panel.

25

Fit the upholstered right side panel

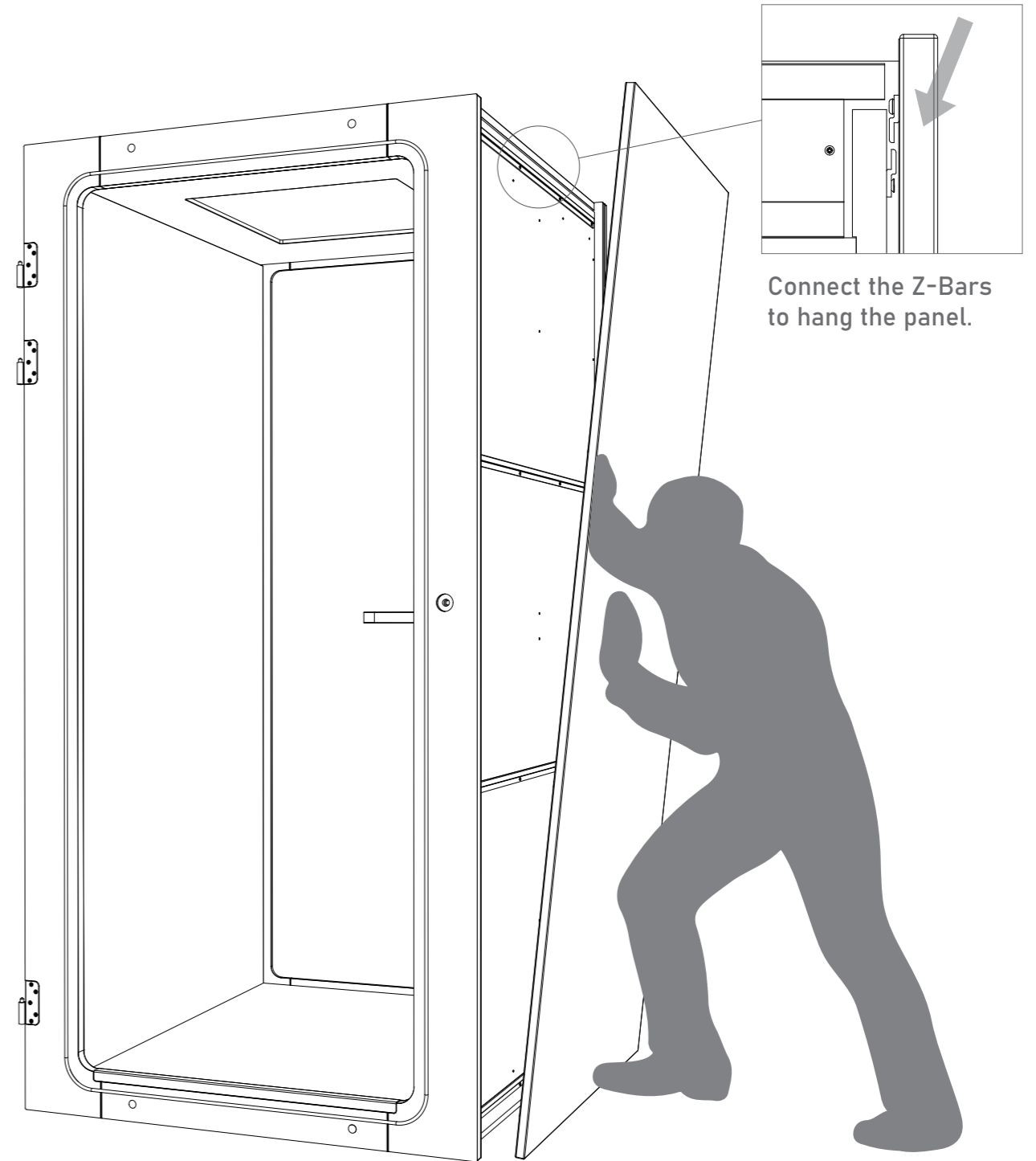

Connect the Z-Bars to hang the panel.

26

Fit door



Heavy!
Two person lift required.

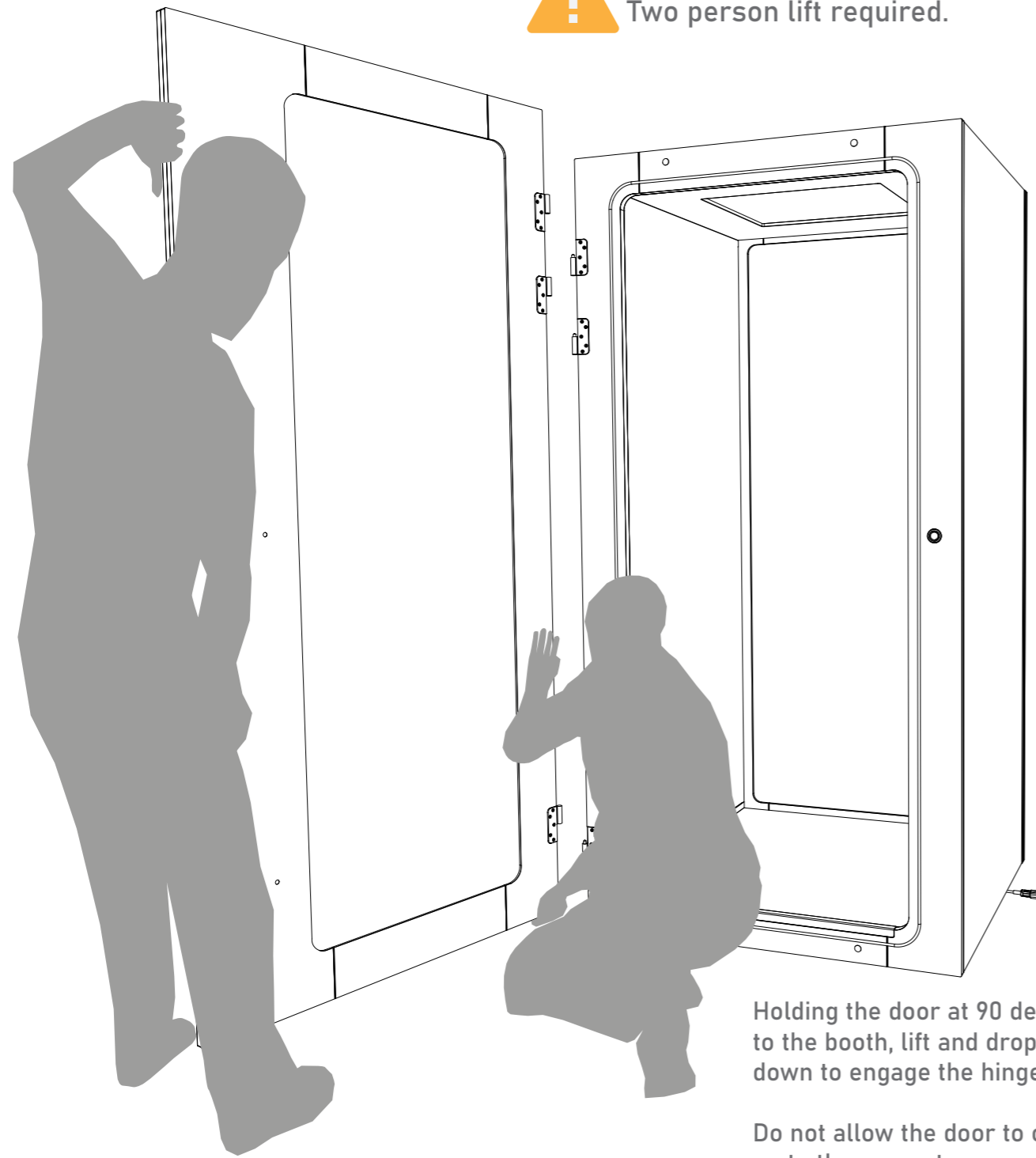





Holding the door at 90 degrees to the booth, lift and drop down to engage the hinges.

Do not allow the door to close on to the magnet.

27

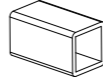
Fit door handles

- 3x  M8 cap head bolt cover
- 3x  M8 x 140mm cap head bolt
- 6x  Door handle spacer
- 3x  M8 x 15mm washer

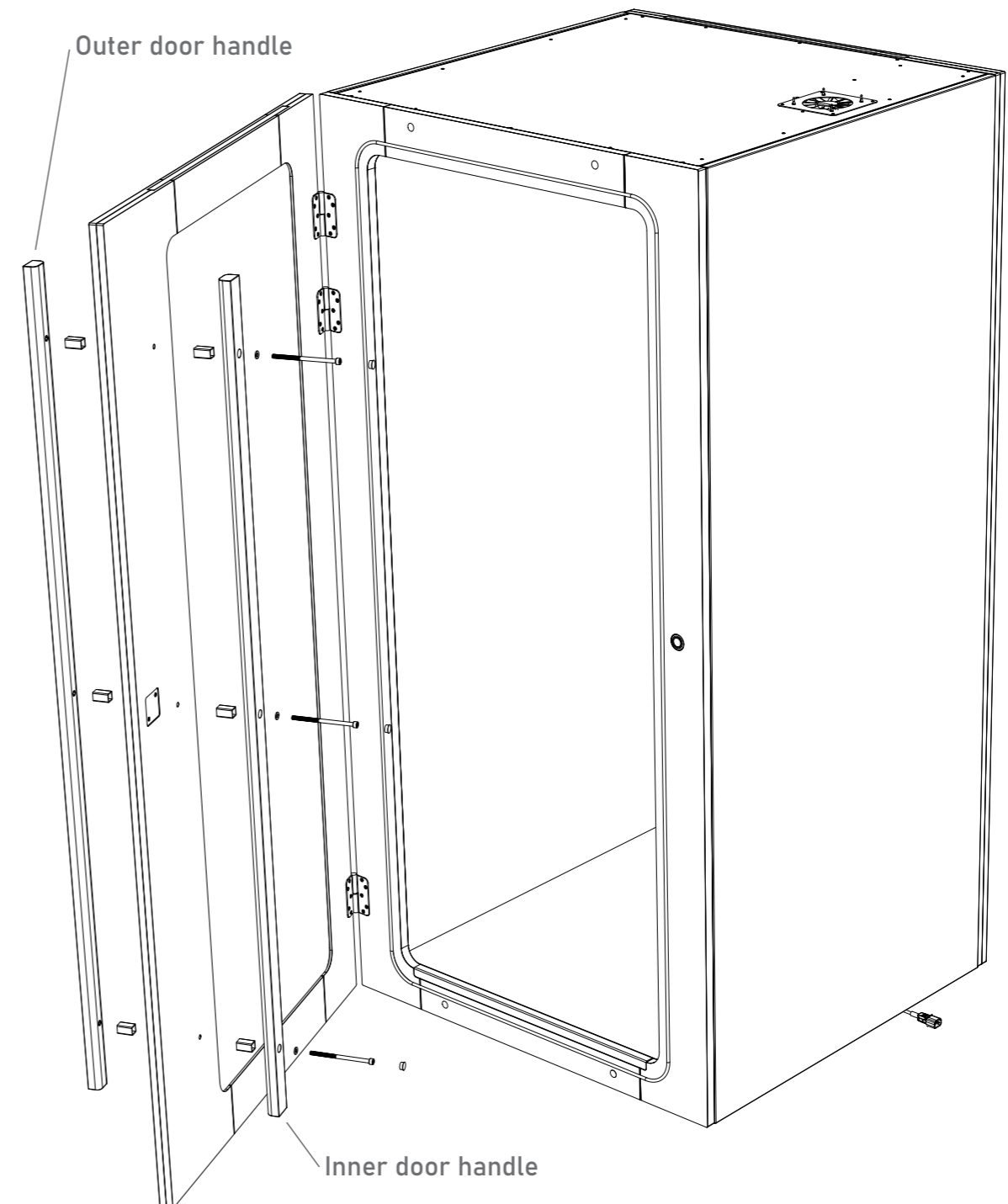

28

Test door seal and magnetic catch

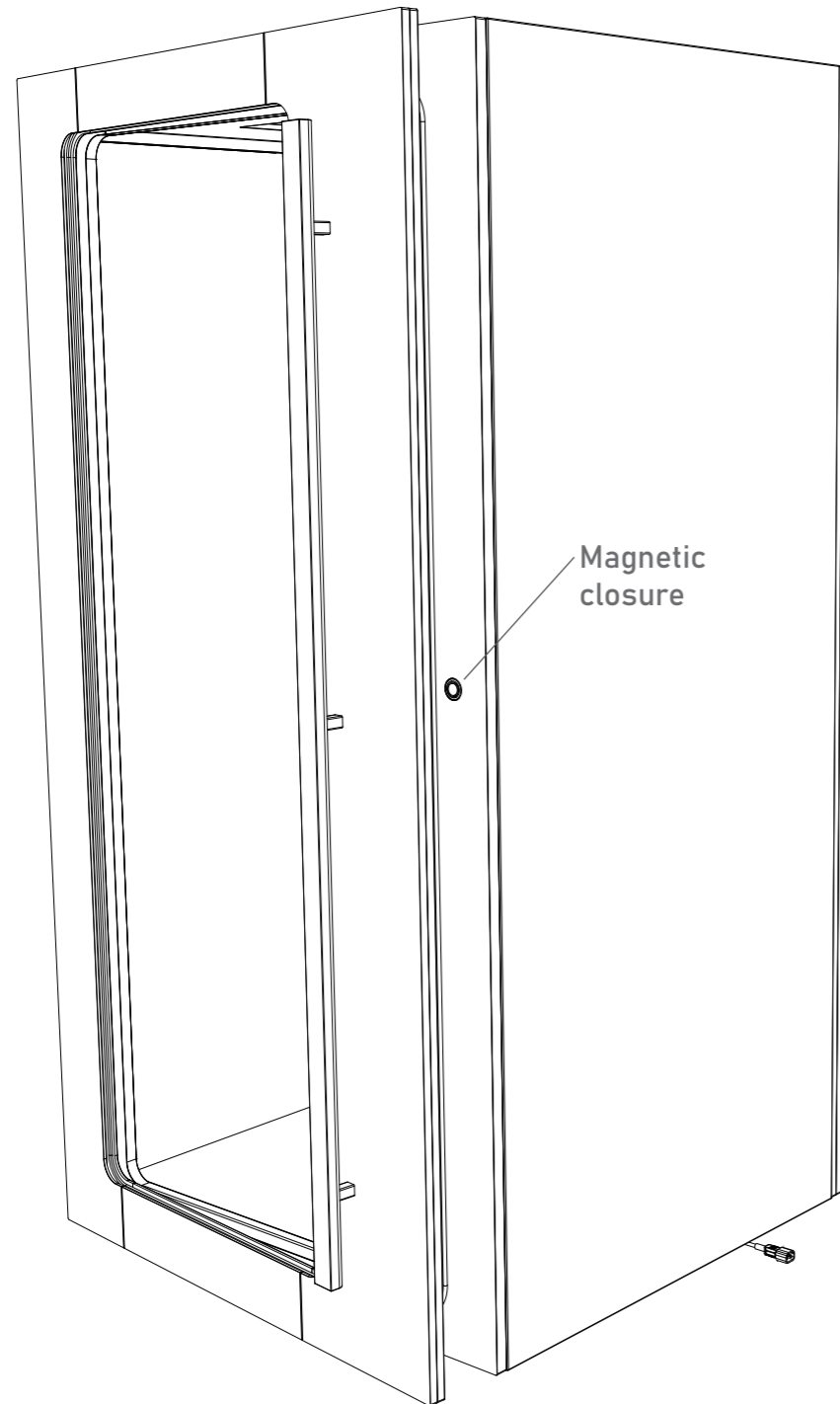

Door should soft close and hold to magnet to provide a good seal.

Door should be easy to open.

For magnet adjustment see STEP 29.

29

Adjust door closure and magnetic catch



3mm Hex key



Plastic magnet spacer shims (0.5mm; 1.0mm)

Magnetic catch assembly

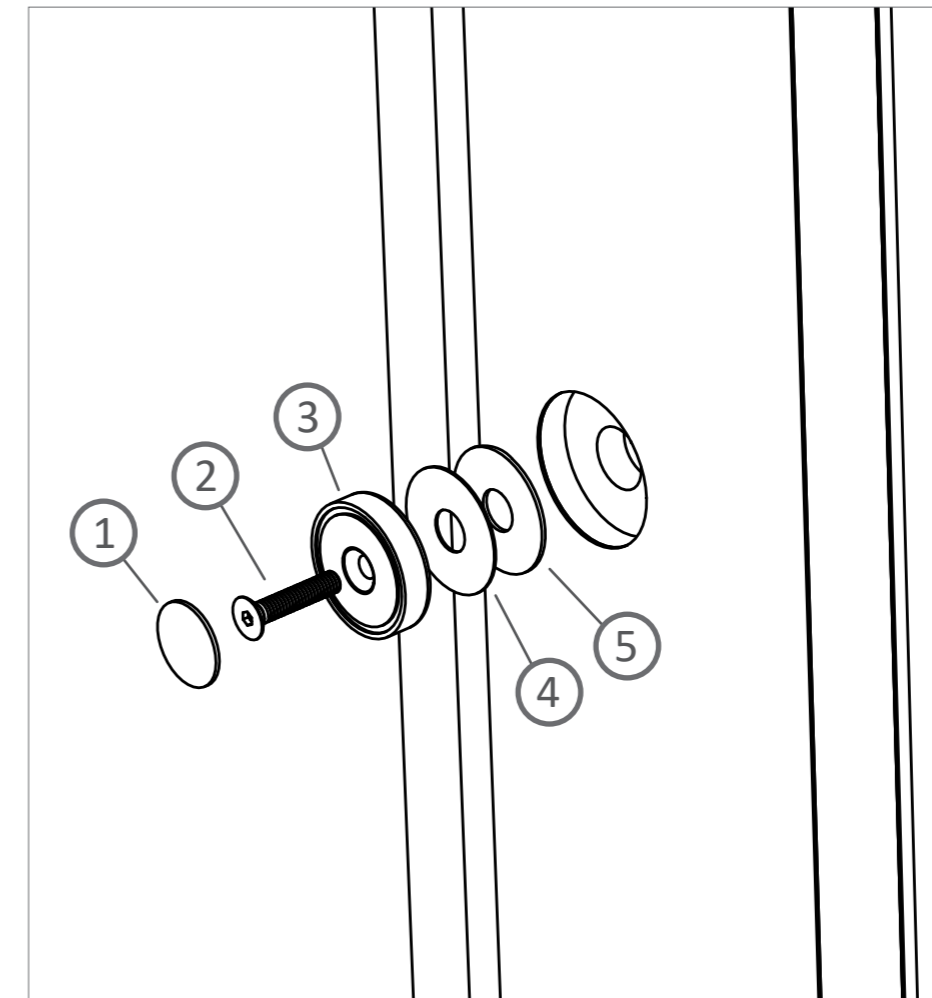

- ① Self-adhesive cover
- ② M5 x 25mm CSK screw
- ③ Magnet
- ④ Plastic shim
- ⑤ Plastic shim

To adjust door seal and magnet closure:

- remove the self-adhesive cover on magnet
- remove the screw and magnet with 3mm allen key
- add or remove plastic spacer shims accordingly
- tighten magnet back into position with the allen key
- replace self-adhesive cover on the magnet
- check the door seal

Screen Solutions[®]
A Gabriel Group company

Tone Acoustic Booth
Assembly Instructions V1.0
Copyright 2022